



<http://www.sony.net/SonyInfo/Support/>

SONY®

4-692-676-11(2)

α9

Interchangeable Lens  
Digital Camera

α9

E-mount

Instruction Manual



**"Help Guide" (Web manual)**

Refer to "Help Guide" for in-depth instructions on the many functions of the camera.

[http://rd1.sony.net/help/ilc/1650/h\\_zz/](http://rd1.sony.net/help/ilc/1650/h_zz/)



4692676110

# Check out the Help Guide!



The “Help Guide” is an on-line manual that you can read on your computer or smartphone. Refer to it for details on menu items, advanced usage, and the latest information on the camera.



Scan here

[http://rd1.sony.net/help/ilc/1650/h\\_zz/](http://rd1.sony.net/help/ilc/1650/h_zz/)

ILCE-9 Help Guide



## Instruction Manual (this book)



This manual introduces some basic functions.

For the quick start guide, see “Startup guide” (page 39). The “Startup guide” introduces the initial procedures from when you open the package until you release the shutter for the first shot.

## In-Camera Guide



The [In-Camera Guide] shows explanations of the menu items on the monitor of the camera.

You can quickly pull up information during shooting.

To use the [In-Camera Guide] function, some settings must be made beforehand. For details, search “In-Camera Guide” in the Help Guide.

### Owner's Record

Record the model and serial number (which are located on the product) in the space provided below. Refer to these numbers whenever you call your Sony dealer regarding this product.

Model No. ILCE-

Serial No. \_\_\_\_\_

### WARNING

To reduce fire or shock hazard, do not expose the unit to rain or moisture.

## IMPORTANT SAFETY INSTRUCTIONS -SAVE THESE INSTRUCTIONS DANGER TO REDUCE THE RISK OF FIRE OR ELECTRIC SHOCK, CAREFULLY FOLLOW THESE INSTRUCTIONS

If the shape of the plug does not fit the power outlet, use an attachment plug adaptor of the proper configuration for the power outlet.

### CAUTION

#### Battery pack

If the battery pack is mishandled, the battery pack can burst, cause a fire or even chemical burns. Observe the following cautions.

- Do not disassemble.
- Do not crush and do not expose the battery pack to any shock or force such as hammering, dropping or stepping on it.
- Do not short circuit and do not allow metal objects to come into contact with the battery terminals.
- Do not expose to high temperature above 60°C (140°F) such as in direct sunlight or in a car parked in the sun.
- Do not incinerate or dispose of in fire.
- Do not handle damaged or leaking lithium ion batteries.
- Be sure to charge the battery pack using a genuine Sony battery charger or a device that can charge the battery pack.
- Keep the battery pack out of the reach of small children.
- Keep the battery pack dry.
- Replace only with the same or equivalent type recommended by Sony.
- Dispose of used battery packs promptly as described in the instructions.
- Do not expose to extremely low temperatures of -20°C (-4°F) or lower or extremely low pressures of 11.6 kPa or lower.

Use a nearby wall outlet (wall socket) when using the AC Adaptor/battery charger. If any malfunction occurs, disconnect the plug from the wall outlet (wall socket) immediately to disconnect from the power source. If you use the product with a charge lamp, note that the product is not disconnected from the power source even when the lamp turns off.

For safety, do not connect the connector for peripheral device wiring that might have excessive voltage to LAN terminal. Follow the instructions for LAN terminal.

The power cord (mains lead), if supplied, is designed specifically for use with this equipment only, and should not be used with other electrical equipment.

### Power Cord

For the customers in the UK, Ireland, Malta, Cyprus and Saudi Arabia Use the power cord (A). For safety reasons, the power cord (B) is not intended for above countries/regions and shall therefore not be used there. For the customers in other EU countries/regions Use the power cord (B).

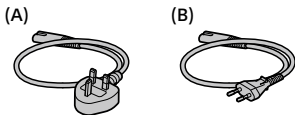

### Notice

If static electricity or electromagnetism causes data transfer to discontinue midway (fail), restart the application or disconnect and connect the communication cable (USB, etc.) again.

This product has been tested and found compliant with the limits set out in the EMC regulation for using connection cables shorter than 3 meters (9.8 feet) except LAN cable.

### LAN cable

Use a Category 5e or higher Shielded Twisted Pair (STP) cable with high shielding performance.

The electromagnetic fields at the specific frequencies may influence the picture and sound of this unit.

## For Customers in the U.S.A. and Canada

### RECYCLING LITHIUM-ION BATTERIES

Lithium-Ion batteries are recyclable.

You can help preserve our environment by returning your used rechargeable batteries to the collection and recycling location nearest you.

For more information regarding recycling of rechargeable batteries, call toll free 1-800-822-8837, or visit <http://www.call2recycle.org/>

**Caution:** Do not handle damaged or leaking Lithium-Ion batteries.





This equipment complies with FCC radiation exposure limits set forth for an uncontrolled environment and meets the FCC radio frequency (RF) Exposure Guidelines. This equipment has very low levels of RF energy that is deemed to comply without testing of specific absorption rate(SAR). The available scientific evidence does not show that any health problems are associated with using low power wireless devices. There is no proof, however, that these low power wireless devices are absolutely safe. Low power Wireless devices emit low levels of radio frequency energy (RF) in the microwave range while being used. Whereas high levels of RF can produce health effects (by heating tissue), exposure of low-level RF that does not produce heating effects causes no known adverse health effects. Many studies of low-level RF exposures have not found any biological effects. Some studies have suggested that some biological effects might occur, but such findings have not been confirmed by additional research. This equipment has been tested and found to comply with IC radiation exposure limits set forth for an uncontrolled environment and meets RSS-102 of the IC radio frequency (RF) Exposure rules.

## For Customers in the U.S.A.

If you have any questions about this product, you may call:

Sony Customer Information Center  
1-800-222-SONY (7669).

The number below is for the FCC related matters only.

### Regulatory Information

#### Declaration of Conformity

Trade Name: SONY

Model No.: WW361847

Responsible Party: Sony Electronics Inc.

Address: 16535 Via Esprillo, San Diego, CA 92127 U.S.A.

Telephone No.: 858-942-2230

This device complies with Part15 of the FCC Rules. Operation is subject to the following two conditions: (1) This device may not cause harmful interference, and (2) this device must accept any interference that received, including interference that may cause undesired operation.

This device complies with Part 15 of the FCC Rules. Operation is subject to the following two conditions:

(1) This device may not cause harmful interference, and (2) this device must accept any interference received, including interference that may cause undesired operation.

This equipment must not be co-located or operated in conjunction with any other antenna or transmitter.

## CAUTION

You are cautioned that any changes or modifications not expressly approved in this manual could void your authority to operate this equipment.

### Note:

This equipment has been tested and found to comply with the limits for a Class B digital device, pursuant to Part 15 of the FCC Rules.

These limits are designed to provide reasonable protection against harmful interference in a residential installation. This equipment generates, uses, and can radiate radio frequency energy and, if not installed and used in accordance with the instructions, may cause harmful interference to radio communications. However, there is no guarantee that interference will not occur in a particular installation. If this equipment does cause harmful interference to radio or television reception, which can be determined by turning the equipment off and on, the user is encouraged to try to correct the interference by one or more of the following measures:

- Reorient or relocate the receiving antenna.
- Increase the separation between the equipment and receiver.
- Connect the equipment into an outlet on a circuit different from that to which the receiver is connected.
- Consult the dealer or an experienced radio/TV technician for help.

The supplied interface cable must be used with the equipment in order to comply with the limits for a digital device pursuant to Subpart B of Part 15 of FCC Rules.

### For Customers in Canada

This device complies with Industry Canada's licence-exempt RSSs. Operation is subject to the following two conditions:

- (1) This device may not cause interference; and
- (2) This device must accept any interference, including interference that may cause undesired operation of the device.

CAN ICES-3 B/NMB-3 B

### For Customers in Europe

Manufacturer: Sony Corporation, 1-7-1 Konan Minato-ku Tokyo, 108-0075 Japan

For EU product compliance: Sony Belgium, bijkantoor van Sony Europe Limited, Da Vincilaan 7-D1, 1935 Zaventem, Belgium



Hereby, Sony Corporation, declares that this equipment is in compliance with the essential requirements and other relevant provisions of Directive 1999/5/EC. For details, please access the following URL:

<http://www.compliance.sony.de/>

**Disposal of waste batteries and electrical and electronic equipment (applicable in the European Union and other European countries with separate collection systems)**



This symbol on the product, the battery or on the packaging indicates that the product and the battery shall not

be treated as household waste. On certain batteries this symbol might be used in combination with a chemical symbol. The chemical symbols for mercury (Hg) or lead (Pb) are added if the battery contains more than 0.0005% mercury or 0.004% lead. By ensuring these products and batteries are disposed of correctly, you will help prevent potentially negative consequences for the environment and human health which could otherwise be caused by inappropriate waste handling. The recycling of the materials will help to conserve natural resources. In case of products that for safety, performance or data integrity reasons require a permanent connection with an incorporated battery, this battery should be replaced by qualified service staff only. To ensure that the battery and the electrical and electronic equipment will be treated properly, hand over these products at end-of-life to the applicable collection point for the recycling of electrical and electronic equipment. For all other batteries, please view the section on how to remove the battery from the product safely. Hand the battery over to the applicable

collection point for the recycling of waste batteries.

For more detailed information about recycling of this product or battery, please contact your local Civic Office, your household waste disposal service or the shop where you purchased the product or battery.

**For Customers in Singapore**

Complies with  
IMDA Standards  
DB00353

**For Customers in U.A.E.**

**TRA**  
**REGISTERED No:**  
ER42682/15  
**DEALER No:**  
DA0073692/11

**For Customers in Malaysia**











# Table of contents









Check out the Help Guide!.....	2
Notes on using your camera.....	16



## Preparations for shooting

Checking the camera and the supplied items .....	21
Identifying parts.....	22
Front side .....	22
Rear side .....	24
Top side/Side view .....	26
Bottom .....	29
Basic operations.....	30
Using the control wheel .....	30
Using the multi-selector.....	31
Using the Fn (Function) button .....	31
How to use the Quick Navi screen .....	32
Changing the screen display .....	35
Switching the screen display (while shooting/during playback) .....	35
DISP Button (Monitor/Finder) .....	37
Startup guide .....	39
Step 1: Charging the battery pack.....	39
Step 2: Inserting the battery pack into the camera.....	40
Step 3: Inserting a memory card.....	41
Step 4: Attaching a lens .....	43
Step 5: Setting the language and the clock.....	46
Step 6: Shooting images in auto mode .....	47





## Shooting

Shooting still images .....	49
Focusing .....	51
Focus Mode .....	51
Auto focus .....	53
Focus Area .....	53
Adjusting the focus area settings to the camera's orientation (horizontal/vertical)	
 Swt. V/H AF Area) .....	57
AF/MF control .....	58
AF On .....	59
Eye AF .....	59
 AF in Focus Mag. ....	60
Center Lock-on AF .....	61
Registering the current focus area	
 AF Area Regist.) .....	63
 Pre-AF .....	64
Priority Set in AF-S .....	65
Priority Set in AF-C .....	65
 AF Illuminator .....	66
AF Micro Adj. ....	67
 AF System .....	68
Manual Focus .....	69
Direct manual focus (DMF) .....	70
Focus Magnifier .....	71
 MF Assist .....	72
Peaking Level .....	73
Shutter setting .....	74
 Shutter Type .....	74
Using the electronic shutter .....	75
Displaying the release timing (Shoot. Timing Disp.) ....	77
Shoot. Start Disp. ....	78
e-Front Curtain Shut. ....	78

Shooting with drive modes	
(continuous shooting/self-timer).....	79
Continuous shooting .....	79
Self-timer .....	82
Self-timer (Cont) .....	83
Cont. Bracket.....	84
Single Bracket .....	85
Indicator during bracket shooting .....	86
WB bracket.....	87
DRO Bracket.....	88
Using touch function .....	90
Touch Operation .....	90
Touch Focus .....	90
Selecting a still image size/image quality .....	92
 Image Size .....	92
 Aspect Ratio .....	93
 Quality .....	93
APS-C/Super 35mm.....	95
Selecting a shooting mode.....	96
List of mode dial function .....	96
<b>AUTO</b> (i  Intelligent Auto).....	97
<b>P</b> Program Auto.....	98
<b>A</b> Aperture Priority.....	99
<b>S</b> Shutter Priority.....	99
<b>M</b> Manual Exposure .....	100
<b>M</b> Bulb shooting.....	102
 1/  2 Recall .....	103
 Movie:  Exposure Mode .....	104
<b>S&amp;Q</b> S&Q Motion: <b>S&amp;Q</b> Exposure Mode.....	105
Controlling the exposure/metering modes .....	106
Exposure Comp.....	106
Metering Mode .....	108
Spot Metering Point.....	109
AE lock .....	110
Zebra .....	111
Correcting brightness and contrast automatically.....	112
D-Range Opt. (DRO) .....	112
Auto HDR .....	113

Selecting the ISO sensitivity .....	115
ISO AUTO Min. SS.....	116
Using the zoom.....	117
The zoom features available with this product .....	117
Clear Image Zoom/Digital Zoom (Zoom) .....	118
About zoom scale.....	119
White Balance .....	120
Capturing a basic white color in [Custom Setup] mode .....	121
Setting how to process images .....	123
Creative Style .....	123
 Color Space.....	126
Reducing blur.....	127
SteadyShot Settings .....	127
Noise reduction.....	129
 Long Exposure NR.....	129
 High ISO NR.....	130
Face Detection .....	131
Using flash (sold separately).....	132
Flash Mode .....	133
Flash Comp. ....	134
FEL lock .....	135
Wireless flash shooting .....	136
Using a flash with a sync terminal cord .....	138

## Shooting movies



Shooting movies .....	139
Changing settings for movie recording.....	142
 File Format.....	142
 Record Setting.....	143
 S&Q Settings.....	147
Audio Recording.....	149
Audio Rec Level .....	150
 Marker Settings.....	151
 4K Output Sel. ....	152

## Viewing

Viewing images .....	153
Playing back still images .....	153
Enlarging an image being played back (Playback zoom).....	154
Rotating recorded images automatically (Display Rotation).....	155
Playing back movies.....	155
Photo Capture.....	157
Playing back images on the image index screen (Image Index) .....	157
Switching between still images and movies (View Mode).....	158
Selecting which memory card to play back (Select PB Media) .....	159
Copying images from one memory card to another (Copy) .....	159
Playing back images using slideshow (Slide Show).....	160
Protecting images (Protect).....	161
Deleting images.....	162
Deleting a displayed image .....	162
Deleting multiple selected images (Delete) .....	162
Viewing images on a TV .....	164
Viewing images on a TV using an HDMI cable .....	164



## Customizing the camera

Registering frequently used functions.....	167
 1/  2 Memory.....	167
Registering shooting settings to a custom key (Reg Cust Shoot Set).....	168
Assigning selected functions to the button.....	170
Custom Key (Shoot.)/Custom Key (PB).....	170
Function Menu Set.....	171
Customizing the MENU (My Menu).....	172
Add Item.....	172
Sort Item.....	172
Delete Item.....	173
Checking images before/after recording.....	174
Auto Review.....	174
Aperture Preview.....	174
Shot. Result Preview.....	175
Monitor/viewfinder settings.....	176
FINDER/MONITOR.....	176
 Finder Frame Rate.....	177
Memory card settings.....	178
Format.....	178
File Number.....	179
Set File Name.....	179
Recording Mode.....	180
Select REC Folder.....	181
Camera settings.....	182
Pwr Save Start Time.....	182
Remote Ctrl.....	182
HDMI Settings.....	183
USB Power Supply.....	187
PC Remote Settings.....	187
Initializing the camera.....	189
Setting Reset.....	189





## Using network functions

Using the Wi-Fi/One-touch (NFC)/Bluetooth/wired LAN functions .....	190
Installing PlayMemories Mobile .....	190
Transferring images to the FTP server .....	191
Connecting the camera and a smartphone .....	192
Using a smartphone as a remote control for the camera .....	192
Transferring images from the camera to a smartphone .....	194
Connecting the camera to a wireless access point .....	195
Recording location information to captured images .....	196
Preparation in advance .....	196
Operating procedure .....	197

## Using a computer

Connecting the camera to a computer .....	200
Selecting the appropriate USB connection method .....	200
Connecting to a computer .....	201
Disconnecting the camera from the computer .....	202
Introduction to computer software .....	203
PlayMemories Home .....	203
Image Data Converter .....	203
Remote Camera Control .....	204

## MENU items/List of icons

Using MENU items .....	205
List of MENU items.....	206
 1 (Camera Settings 1).....	206
 2 (Camera Settings 2).....	211
 (Network).....	214
 (Playback) .....	216
 (Setup).....	217
★ (My Menu).....	220
List of icons on the monitor.....	221

## If you have problems

Troubleshooting.....	226
Warning messages .....	234

## About this product

Cleaning the image sensor.....	238
Mount Adaptor.....	240
LA-EA1/LA-EA3 Mount Adaptor .....	241
LA-EA2/LA-EA4 Mount Adaptor.....	242
Vertical grip .....	244
Specifications .....	245
Battery life and number of recordable images.....	245
Memory cards that can be used .....	246
Number of recordable images .....	247
Recordable movie times.....	249
Specifications.....	252

<b>Index.....</b>	<b>258</b>
-------------------	------------

# Notes on using your camera

Along with this section, also see “Precautions” in the Help Guide (page 2).

## Screen language

You can select the language displayed on the screen using the menu (page 218).

## Notes on recording/playback

- Once you format the memory card, all the data recorded on the memory card will be deleted and cannot be restored. Before formatting, copy the data to a computer or other device.
- Before you start recording, make a trial recording to make sure that the camera is working correctly.

## Notes on handling the product

- This camera is designed to be dust and moisture-resistant, but is not waterproof or splash-proof.
- Do not leave the camera, the supplied accessories, or memory cards within the reach of infants. They may be accidentally swallowed. If this occurs, consult a doctor immediately.

## No compensation for damaged content or recording failure

Sony can provide no guarantees in the event of failure to record or loss or damage of recorded images or audio data due to a malfunction of the camera or recording media, etc. We recommend backing up important data.

## Notes on the monitor, electronic viewfinder, lens, and image sensor

- The monitor and electronic viewfinder are manufactured using extremely high-precision technology, and over 99.99% of the pixels are operational for effective use. However, there may be some small black dots and/or bright dots (white, red, blue or green in color) that constantly appear on the monitor and electronic viewfinder. These dots are normal due to the manufacturing process and do not affect the images in any way.
- Do not hold the camera by the monitor.
- When using the power zoom lens, be careful not to get your fingers or any other objects caught in the lens.
- Do not leave the lens or the viewfinder exposed to a strong light source such as sunlight. Because of the lens's condensing function, doing so may cause smoke, fire, or a malfunction inside the camera body or the lens. If you have to leave the camera exposed to a light source such as sunlight, attach the lens cap to the lens.
- When you shoot with backlighting, keep the sun sufficiently far away from the angle of view. Otherwise, the sunlight may enter the focus inside the camera and cause smoke or fire. Even if the sun is slightly away from the angle of view, it may still cause smoke or fire.

- Do not directly expose the lens to beams such as laser beams. That may damage the image sensor and cause the camera to malfunction.
- Do not look at sunlight or a strong light source through the lens when it is detached. This may result in unrecoverable damage to the eyes or cause a malfunction.
- Do not use the camera in areas where strong radio waves or radiation are being emitted. Recording and playback may not function correctly.
- Images may trail across on the screen in a cold location. This is not a malfunction.
- The recorded image may be different from the image you monitored before recording.

### **Notes on using lenses and accessories**

It is recommended that you use Sony lenses/accessories designed to suit the characteristics of this camera. Using this camera with products from other manufacturers may affect its performance, leading to accidents or malfunction. Sony bears no responsibility for such accidents or malfunction.

### **Notes on the Multi Interface Shoe**

- When attaching or detaching accessories such as an external flash to the Multi Interface Shoe, first turn the power to OFF. When attaching the accessory, confirm that it is firmly fastened to the camera.
- Do not use the Multi Interface Shoe with a commercially available flash that applies voltages of 250 V or more or has the opposite polarity of the camera. It may cause a malfunction.

### **Notes on shooting with an external flash**

When shooting with an external flash, light and dark stripes may appear on the image if the shutter speed is set to faster than 1/4000 seconds.

### **Notes on shooting with the viewfinder**

- The image may be slightly distorted near the corners of the viewfinder. This is not a malfunction. When you want to see the full composition with all its details, you can also use the monitor.
- If you pan the camera while looking into the viewfinder or move your eyes around, the image in the viewfinder may be distorted or the color of the image may change. This is a characteristic of the lens or display device and is not a malfunction. When you shoot an image, we recommend that you look at the center area of the viewfinder.

- When shooting with the viewfinder, you may experience symptoms such as eyestrain, fatigue, travel sickness, or nausea. We recommend that you take a break at regular intervals when you are shooting with the viewfinder. In case you may feel uncomfortable, refrain from using the viewfinder until your condition recovers, and consult your doctor as necessary.

### **Notes on continuous shooting**

During continuous shooting, the monitor or viewfinder may flash between the shooting screen and a black screen. If you keep watching the screen in this situation, you may experience uncomfortable symptoms such as feeling of unwellness. If you experience uncomfortable symptoms, stop using the camera, and consult your doctor as necessary.

### **Notes on recording for long periods of time or recording 4K movies**

- Depending on the camera and battery temperature, you may be unable to record movies or the power may turn off automatically to protect the camera. A message will be displayed on the screen before the power turns off or you can no longer record movies. In this case, leave the power off and wait until the camera and battery temperature goes down. If you turn on the power without letting the camera and battery cool enough, the power may turn off again or you may be unable to record movies.
- Under high ambient temperatures, the temperature of the camera rises quickly.
- When the temperature of the camera rises, the image quality may deteriorate. It is recommended that you wait until the temperature of the camera drops before continuing to shoot.
- The surface of the camera may get warm. This is not a malfunction.
- If the same part of your skin touches the camera for a long period of time while using the camera, even if the camera does not feel hot to you, it may cause symptoms of a low-temperature burn such as redness or blistering.

Pay special attention in the following situations and use a tripod, etc.

- When using the camera in a high-temperature environment
  - When someone with poor circulation or impaired skin sensation uses the camera
  - When using the camera with the [Auto Pwr OFF Temp.] set to [High].
- Especially during 4K movie shooting, the recording time may be shorter under low temperature conditions. Warm up the battery pack or replace it with a new battery.

### Notes on playing back movies on other devices

Movies recorded with this camera may not be played back correctly on other devices. Also, movies recorded with other devices may not be played back correctly on this camera.

### Warning on copyright

Television programs, films, videotapes, and other materials may be copyrighted. Unauthorized recording of such materials may be contrary to the provisions of the copyright laws.

### On the data specifications described in this manual

The data on performance and specifications are defined under the following conditions, except as described in this manual: at an ordinary ambient temperature of 25°C (77°F), and using a battery pack that has been fully charged until the charge lamp has turned off.

### How to turn off wireless network functions (Wi-Fi, NFC and Bluetooth function, etc.) temporarily

When you board an airplane, etc., you can turn off all wireless network functions temporarily.

Select MENU button →  (Network) → [Airplane Mode] → [On].

If you set [Airplane Mode] to [On], an  (airplane) mark will be displayed on the screen.

### Notes on wireless LAN

If your camera is lost or stolen, Sony bears no responsibility for the loss or damage caused by illegal access or use of the registered access point on the camera.

### Notes on security when using wireless LAN products

- Always make sure that you are using a secure wireless LAN to avoid hacking, access by malicious third parties, or other vulnerabilities.
- It is important that you set the security settings when using a wireless LAN.
- If a security problem arises because no security precautions are in place or due to any inevitable circumstances when using a wireless LAN, Sony bears no responsibility for the loss or damage.

## **Notes on discarding or transferring this product to others**

When discarding or transferring this product to others, make sure to perform the following operation to protect private information.

- Select [Setting Reset] → [Initialize] → [OK] → [OK].

## **Notes on discarding or transferring a memory card to others**

Executing [Format] or [Delete] on the camera or a computer may not completely delete the data on the memory card. When transferring a memory card to others, we recommend that you delete the data completely using data deletion software. When discarding a memory card, we recommend that you physically destroy it.

## **Notes on location information**

If you upload and share an image tagged with a location, you may accidentally reveal the information to a third party. To prevent third parties from obtaining your location information, set [ Loc. Info. Link Set.] to [Off] before shooting images.



## Checking the camera and the supplied items

The number in parentheses indicates the number of pieces.

- Camera (1)

- AC Adaptor (1)

The shape of the AC Adaptor may differ depending on the country/region.

- Battery charger (1)



- Power cord (mains lead) (1)\*



\* Multiple power cords may be supplied with your camera. Use the appropriate one that matches your country/region. See page 4.

- Rechargeable battery pack NP-FZ100 (1)



- Micro USB cable (1)

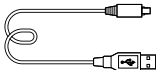

- Shoulder strap (1)

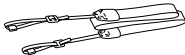

- Body cap (1) (Attached to the camera)



- Cable protector (1)



- Shoe cap (1) (Attached to the camera)

- Eyepiece cup (1) (Attached to the camera)



- Instruction Manual (1) (this manual)

# Identifying parts

See the pages in parentheses for details.

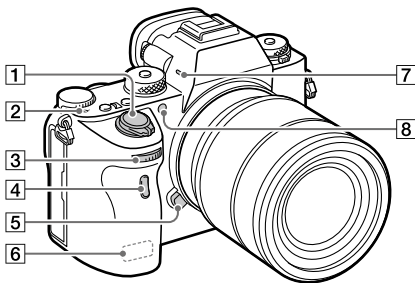
## Front side



- 1 ON/OFF (Power) switch (46)/Shutter button (49)
- 2  Image sensor position mark
  - The image sensor is the sensor that converts light into an electric signal. The  mark shows the location of the image sensor. When you measure the exact distance between the camera and the subject, refer to the position of the horizontal line.

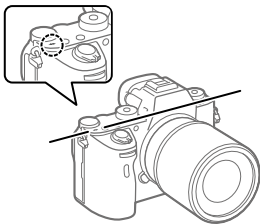

- If the subject is closer than the minimum shooting distance of the lens, the focus cannot be confirmed. Make sure you put enough distance between the subject and the camera.

- 3 Front dial**  
You can quickly adjust the settings for each shooting mode.
- 4 Remote sensor**
- 5 Lens release button (45)**
- 6 Wi-Fi antenna (built-in)**
- 7 Microphone\***
- 8 AF illuminator (66)/Self-timer lamp (82)**

### When the lens is removed

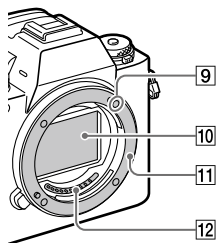

- 9 Mounting index (44)**
- 10 Image sensor\*\***
- 11 Mount**
- 12 Lens contacts \*\***

\* Do not cover this part during movie recording. Doing so may cause noise or lower the volume.

\*\* Do not directly touch these parts.

## Rear side

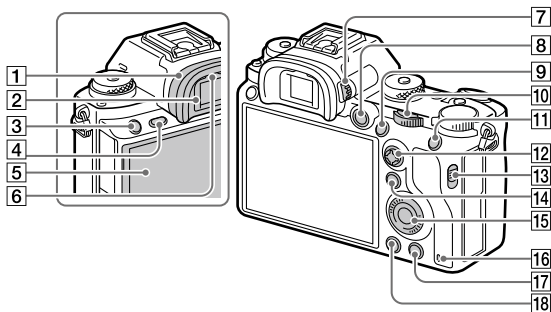

### 1 Eyepiece cup

#### To remove the eyepiece cup

Push the grips at the bottom of the eyepiece cup to the left and right and lift up the cup.

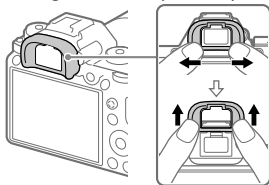

Remove the eyepiece cup when attaching an angle viewfinder (sold separately). Also, select MENU → 2 (Camera Settings 2) → [FINDER/MONITOR], and then switch [Viewfinder (Manual)] and [Monitor (Manual)].

### 2 Viewfinder

### 3 C3 button (Custom button 3) (170)

### 4 MENU button (205)

### 5 Monitor/Touch panel (35, 90)

You can adjust the monitor to an easily viewable angle and shoot from any position.

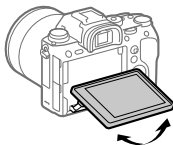

### 6 Eye sensor (176)

**7 Diopter-adjustment dial**

Adjust the diopter-adjustment dial according to your eyesight until the display appears clearly in the viewfinder. If it is hard to operate the diopter-adjustment dial, remove the eyepiece cup before operating the dial.

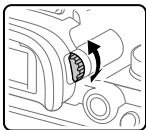
**8 MOVIE (Movie) button (139)****9 For shooting: AF-ON (AF On) button (59)**

For viewing:  (Enlarge) button (154)

**10 Rear dial**

You can quickly adjust the settings for each shooting mode.

**11 For shooting: AEL button (110)**

For viewing:  (Image index) button (157)

**12 Multi-selector (31)****13 Media slot cover switch****14 For shooting: Fn (Function) button (31, 171)**

For viewing:  (Send to Smartphone) button

You can display the screen for [Send to Smartphone] by pressing this button.

**15 Control wheel****16 Access lamp****17 For shooting: C4 button (Custom button 4) (170)**



For viewing:  (Delete) button (162)

**18  (Playback) button (153)**

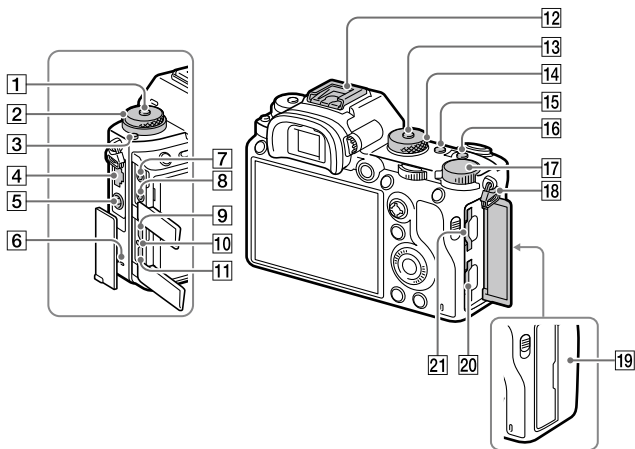
## Top side/Side view



- 1 Drive mode dial lock release button
- 2 Upper: Drive mode dial (79)  
Lower: Focus mode dial (51)
- 3 Focus mode dial lock release button
- 4 LAN terminal
- 5 ⚡ (Flash sync) terminal (138)
- 6 Speaker

- 7  (Microphone) jack  
When an external microphone is connected, the built-in microphone turns off automatically. When the external microphone is a plugin-power type, the power of the microphone is supplied by the camera.
- 8  (Headphones) jack
- 9 HDMI micro jack (164)
- 10 Charge lamp
- 11 Multi/Micro USB Terminal\* (201)  
This terminal supports Micro USB-compatible devices.

- 12 Multi Interface Shoe\* (132)**  
Some accessories may not go in all the way and protrude backward from the Multi interface shoe. However, when the accessory reaches the front end of the shoe, the connection is completed.
- 13 Mode dial lock release button**
- 14 Mode dial (96)**
- 15 C2 button (Custom button 2) (170)**
- 16 C1 button (Custom button 1) (170)**
- 17 Exposure compensation dial (106)**
- 18 Hooks for shoulder strap**  
Attach both ends of the strap onto the camera.

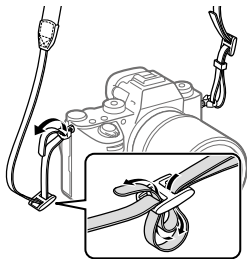

- 19 N (N mark) (190)**
- This mark indicates the touch point for connecting the camera and an NFC-enabled Smartphone.

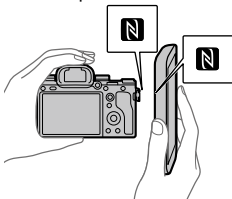

- NFC (Near Field Communication) is an international standard of short-range wireless communication technology.
- 20 SLOT 1 (Memory card slot 1) (41)**  
Supports SD cards only (compatible with UHS-I and UHS-II)
- 21 SLOT 2 (Memory card slot 2) (43)**  
Supports SD cards (compatible with UHS-I) and Memory Stick PRO Duo media

- \* For details on compatible accessories for the multi interface shoe and the Multi/Micro USB Terminal, visit the Sony website, or consult your Sony dealer or local authorized Sony service facility. Accessories for the Accessory Shoe can also be used. Operations with other manufactures' accessories are not guaranteed.

**mi** Multi  
Interface Shoe

**Accessory Shoe**

### To attach the cable protector

Use the cable protector to prevent the HDMI cable from being disconnected when shooting images connected by the HDMI cable. Open both of the jack covers and insert an HDMI cable into the camera. Swing the HDMI micro jack cover downward and attach the cable protector as illustrated so that the end of the cable protector fits in the slit under the Multi/Micro USB Terminal. Secure the cable protector with the attachment screw. Then secure the HDMI cable with the fixing dial.

Attachment screw

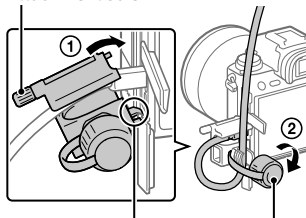

Fit the end in the slit

Fixing dial



## Bottom

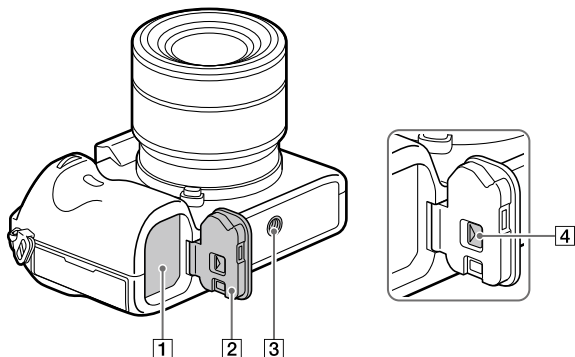

- 1 Battery insertion slot (40)**
- 2 Battery cover (40)**
- 3 Tripod socket hole**  
Use a tripod with a screw less than 5.5 mm (7/32 inches) long. Otherwise, you cannot firmly secure the camera, and damage to the camera may occur.
- 4 Battery cover release lever**

# Basic operations

## Using the control wheel

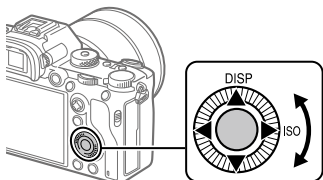

- You can select setting items by turning or pressing the top/bottom/left/right side of the control wheel. Your selection is determined when you press the center of the control wheel.
- The DISP (Display Setting) and ISO (ISO) functions are assigned to the top/right side of the control wheel. In addition, you can assign selected functions to the left/right/bottom side and the center of the control wheel, and to the rotation of the control wheel.
- During playback, you can display the next/previous image by pressing the right/left side of the control wheel or by turning the control wheel.

## Using the multi-selector

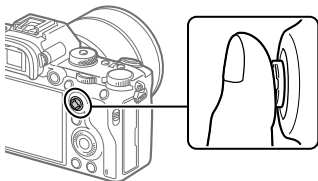

- Put your finger right on top of the multi-selector to manipulate it more precisely.
- When [Focus Area] is set to [Zone], [Flexible Spot], or [Expand Flexible Spot], you can move the focus area by pressing the multi-selector up/down/left/right.
- The [Focus Standard] function is assigned to the center of the multi-selector in the default settings.

## Using the Fn (Function) button

You can register frequently used functions to the Fn (function) button and recall them while shooting. Up to 12 frequently used functions can be registered to the Fn (Function) button.

- 1 Press the DISP on the control wheel repeatedly to display a screen mode other than [For viewfinder], and then press the Fn (Function) button.**

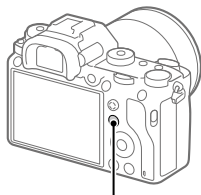

Fn button

- 2 Select the desired function by pressing the top/bottom/left/right side of the control wheel.**

---

### 3 Select the desired setting by turning the front dial, and press the center of the control wheel.

- Some functions can be fine-tuned using the rear dial.

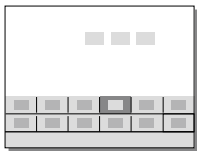

---

### To adjust settings from the dedicated setting screens

Select the desired function in step 2, then press the center of the control wheel. The dedicated setting screen for the function will appear. Follow the operating guide to adjust settings.



Operation guide

## How to use the Quick Navi screen

The Quick Navi screen is a function optimized for shooting with the viewfinder, that lets you control settings directly.

- 
- 1 Select **MENU** → 2 (Camera Settings 2) → [DISP Button] → [Monitor] → place a ✓ mark on [For viewfinder] and then select [Enter].
  - 2 Press the **DISP** on the control wheel to set the screen mode to [For viewfinder] (page 38).

### 3 Press the Fn button to switch to the Quick Navi screen.

- The displayed contents and their positions in the illustrations are just guidelines, and may differ from the actual displays.

#### Auto mode



#### P/A/S/M mode



### 4 Select a function to set by pressing the top/bottom/left/right side of the control wheel.

### 5 Select the desired setting by turning the front dial.

- Some functions can be fine-tuned using the rear dial.

## To adjust settings from the dedicated setting screens

Select the desired function in step 4, then press the center of the control wheel. The dedicated setting screen for the function will appear. Follow the operating guide to adjust settings.



Operation guide

### Note

- Items that are gray on the Quick Navi screen are not adjustable.
- When using [Creative Style], some settings can only be controlled from the dedicated screen.

# Changing the screen display

## Switching the screen display (while shooting/during playback)

You can change the display contents on the screen.

### Press the DISP (Display Setting) button.

- To switch the information displayed on the viewfinder, press the DISP button while looking into the viewfinder.
- Each time you press the DISP button, the screen display changes.
- The displayed contents and their position are just a guideline, and may differ from the actual display.

### During shooting (Monitor)

Display All Info.



No Disp. Info.

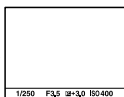

Histogram

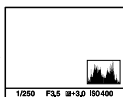

For viewfinder

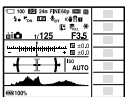

Level

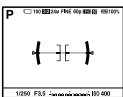

### During shooting (Viewfinder)

Level

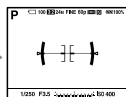

No Disp. Info.



Histogram

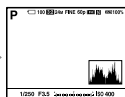

## During playback (Monitor/Viewfinder)

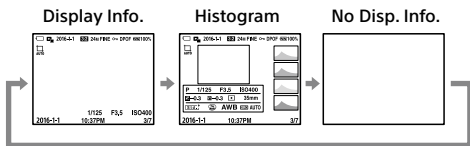

- If the image has an overexposed or underexposed area, the corresponding section will blink on the histogram display (overexposed/underexposed warning).
- The settings for playback are also applied in [Auto Review].

## Histogram display

A histogram shows the luminance distribution, displaying how many pixels there are by luminance. It shows darker toward the left and brighter toward the right.

The histogram changes depending on the exposure compensation.

A peak at the right or left end of the histogram indicates that the image has an overexposed or underexposed area, respectively. You cannot correct such defects using a computer after shooting. Perform exposure compensation before shooting as necessary.

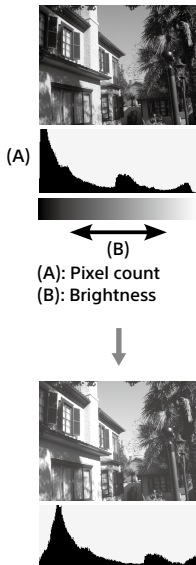



**Note**

- The viewfinder display and the monitor display for shooting can be set separately. Look through the viewfinder to set the display settings for the viewfinder.
- The information in the histogram display does not indicate the final photograph. It is information about image displayed on the screen. The final result depends on the aperture value, etc.
- The histogram display is extremely different between shooting and playback in the following cases:
  - When the flash is used
  - When shooting a low luminance subject such as a night scene
- In movie mode, [For viewfinder] cannot be displayed.

**Hint**

- The following are not displayed in the default settings.
  - Graphic Display
  - Display All Info. (when using the viewfinder)

To change the display modes that are switched when you press the DISP button, select MENU →  2 (Camera Settings 2) → [DISP Button] and change the setting.

**DISP Button (Monitor/Finder)**

Allows you to set the screen display modes that can be selected using DISP (Display Setting) in shooting mode.

**MENU** →  2 (Camera Settings 2) → [DISP Button] → [Monitor] or [Finder] → **desired setting** → [Enter].

The items marked with ✓ are available.

**Graphic Display:** Shows basic shooting information. Graphically shows the shutter speed and aperture value.

**Display All Info.:** Shows recording information.

**No Disp. Info.:** Does not show recording information.

**Histogram:** Displays the luminance distribution graphically.

**Level:** Indicates whether the product is level in both the front-back and horizontal directions. When the product is level in both directions, the indicator turns to green.

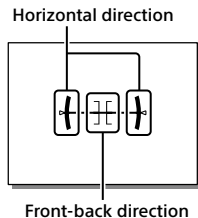

**For viewfinder\*:** Displays information suited for shooting with the viewfinder.

\* This screen mode is available only in the setting for [Monitor].

---

#### Note

- If you tilt the product forward or backward by a large degree, the level error will be great.
- The product may have a margin of error of almost  $\pm 1^\circ$  even when the inclination is corrected by the level.

# Startup guide

## Step 1: Charging the battery pack

### 1 Insert the battery pack into the battery charger.

- Place the battery pack on the battery charger in the direction of the ▲.
- Slide the battery pack in the direction of the arrow as far as it will go.

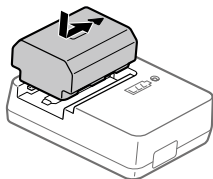

### 2 Connect the power cord (supplied) to the battery charger, and connect the battery charger to the wall outlet (wall socket).

The CHARGE lamp on the battery charger will light up in orange and charging will start.

#### CHARGE lamp (orange)

Lit: Charging

Flashing: Charging error or charging paused temporarily because the camera is not within the proper temperature range

- When charging is finished, the CHARGE lamp and all indicators turn off.
- Charging time (full charge): approximately 150 min. (when charging a fully depleted battery pack at a temperature of 25°C (77°F))
- When you use a completely new battery pack or a battery pack that has not been used for a long time, the CHARGE lamp may flash quickly when the battery is charged for the first time. If this happens, remove the battery pack and then re-insert it to recharge.
- Be sure to use only genuine Sony brand battery packs.

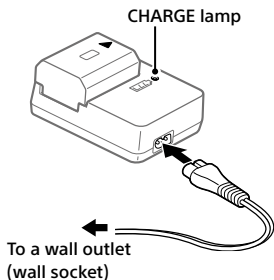

## Step 2: Inserting the battery pack into the camera

**1** Open the battery cover.

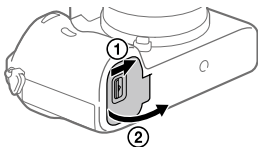

**2** Insert the battery pack while pressing the lock lever with the tip of the battery until the battery locks into place.

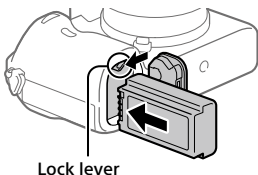

**3** Close the cover.

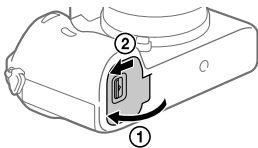

## ■ To charge the battery pack while it is inserted in the camera

Turn the camera off and connect it to the AC Adaptor (supplied) using the micro USB cable (supplied), then connect the AC Adaptor to the wall outlet (wall socket).

If you turn on the camera, power will be supplied from the wall outlet (wall socket) and you will be able to operate the camera. However, the battery pack will not be charged.

## ■ To remove the battery pack

Make sure that the access lamp (page 25) is not lit, and turn off the camera. Then, slide the lock lever and remove the battery pack. Be careful not to drop the battery pack.

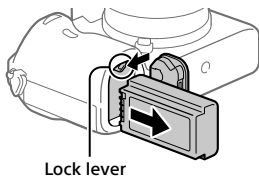

## Step 3: Inserting a memory card

For details on memory cards that can be used with this camera, refer to page 246.

### 1 Open the memory card cover.

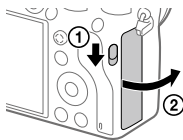

---

## 2 Insert the SD card into the slot 1.

Slot 1 (lower): Supports SD cards (compatible with UHS-I and UHS-II)

Slot 2 (upper): Supports SD cards (compatible with UHS-I) and Memory Stick PRO Duo media

- With the notched corner facing in the direction illustrated, insert the memory card until it clicks into place.
- You can change which memory card slot to use by selecting MENU →  (Setup) → [Select Rec. Media].  
The slot 1 is used in the default settings.
- Use the slot 1 when you are only using one SD card.
- Use the slot 2 when you are using Memory Stick media. In this case, set [Select Rec. Media] to [Slot 2].

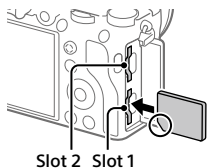

---

## 3 Close the cover.

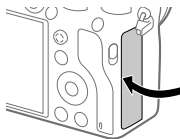

---

### Hint

- When you use a memory card with the camera for the first time, it is recommended that you format the card on the camera for more stable performance of the memory card (page 178).

### Note

- Do not insert a Memory Stick media into the slot 1. It may cause a malfunction.

## To remove the memory card

Open the memory card cover.  
Make sure that the access lamp (page 25) is not lit, and then push in the memory card once to remove it.

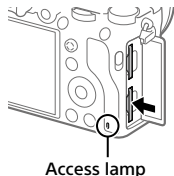

## To record to memory cards in two slots

The slot 1 is used in the default settings. If you do not intend to change the settings and will only use one memory card, use the slot 1.  
By inserting another memory card into the slot 2, you can record the same images to two memory cards simultaneously or record a different type of image (still images/movies) to each memory card ([Recording Mode] (page 180)).

## Step 4: Attaching a lens

### 1 Remove the body cap from the camera and the rear lens cap from the rear of the lens.

- When changing the lens, work quickly in a dust-free environment to keep dust or debris from getting inside the camera.

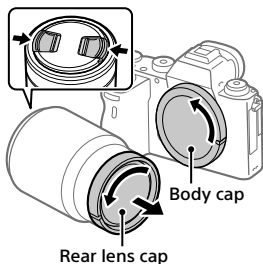

---

## 2 Mount the lens by aligning the two white index marks (mounting indexes) on the lens and camera.

- Hold the camera with the lens facing down to prevent dust or debris from entering the camera.

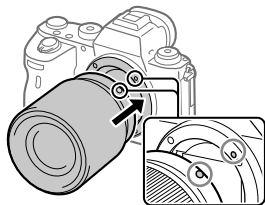

---

## 3 While pushing the lens lightly toward the camera, turn the lens slowly in the direction of the arrow until it clicks into the locked position.

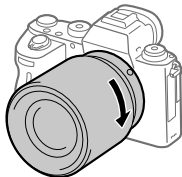

---

### Note

- Be sure to hold the lens straight and do not use force when attaching a lens.
- Do not press the lens release button when attaching a lens.
- The Mount Adaptor (sold separately) is required to use an A-mount lens (sold separately). For details, refer to the operating manual supplied with the Mount Adaptor.
- If you want to shoot full-frame images, use a full-frame size compatible lens.
- When carrying the camera with a lens attached, hold both the camera and the lens firmly.
- Do not hold the part of the lens that is extended for zoom or focus adjustment.



## To remove the lens

Keep pressing the lens release button and turn the lens in the direction of the arrow until it stops.

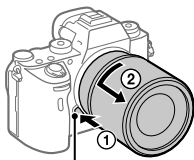

Lens release button

## Compatible lenses

Lenses compatible with this camera are as follows:

Lens		Compatibility with the camera
<b>A-mount lens</b>	Lens compatible with 35 mm full-frame format	✓ (A Mount Adaptor (sold separately) compatible with full-frame format is required)
	APS-C size dedicated lens	✓* (A Mount Adaptor (sold separately) is required)
<b>E-mount lens</b>	Lens compatible with 35 mm full-frame format	✓
	APS-C size dedicated lens	✓*

\* Images will be recorded in APS-C size. The angle of view will correspond to approximately 1.5 times the focal length indicated on the lens. (For example, the angle of view will correspond to 75 mm when a 50 mm-lens is attached.)

## Step 5: Setting the language and the clock

- 1 Set the ON/OFF (Power) switch to "ON" to turn on the camera.

ON/OFF (Power) switch

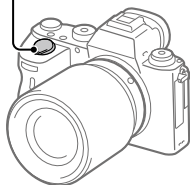

- 
- 2 Select the desired language and then press the center of the control wheel.

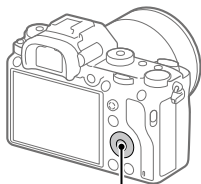

Control wheel

- 
- 3 Make sure that [Enter] is selected on the screen and then press the center.
- 
- 4 Select the desired geographic location and then press the center.
- 
- 5 Select [Date/Time] using the top/bottom of the control wheel or by turning the control wheel, and then press the center.
- 
- 6 Select the desired item by pressing the top/bottom/left/right side of the control wheel, and then press the center.

---

**7 Repeat steps 5 and 6 to set other items, then select [Enter] and press the center.**

---

**Hint**

- To reset the date and time setting, use MENU (page 218).

**Note**

- This camera does not have a function for inserting the date into images. You can insert the date into images and then save and print them using PlayMemories Home (for Windows only).

## Step 6: Shooting images in auto mode

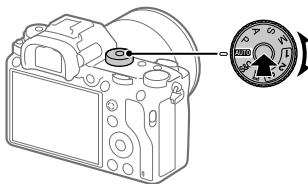

---

**1 Press and hold the lock release button in the center of the mode dial, then turn the mode dial to set to **AUTO**.**  
The shooting mode will be set to **i** (Intelligent Auto).

---

**2 Look through the viewfinder and hold the camera.**

---

**3 Set the size of the subject by rotating the zoom ring of the lens when a zoom lens is attached.**

---

**4 Press the shutter button halfway down to focus.**  
• When the image is in focus, an indicator (such as ●) will light up.

---

**5 Press the shutter button all the way down.**

---

## ■ To shoot movies

Press the MOVIE button to start/stop recording.

## ■ To play back images

Press the  (Playback) button to play back images. You can select the desired image using the control wheel.

## ■ To delete displayed image

Press the  (Delete) button while an image is displayed to delete it. Select [Delete] using the control wheel on the confirmation screen, and then press the center of the control wheel to delete the image.

## ■ To shoot images in various shooting modes

Set the mode dial to the desired mode depending on the subject or the functions you want to use (page 96).

## Shooting still images

### 1 Select the desired shooting mode by turning the mode dial.

- Turn the mode dial while pressing the mode dial lock release button in the center of the mode dial.

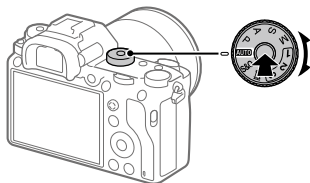

### 2 Adjust the monitor angle, and hold the camera. Or look through the viewfinder and hold the camera.

### 3 When a zoom lens is mounted, enlarge images by rotating the zoom ring.

### 4 Press the shutter button halfway down to focus.

When the image is in focus, a beep sounds and the indicator (such as ●) lights up.

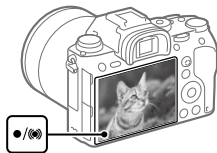

### 5 Press the shutter button fully down.

## To shoot images with the focus locked on the desired subject (Focus-lock)

Shoots images with the focus locked on the desired subject in auto focus mode.

### ① Turn the focus mode dial to select AF-S (Single-shot AF).

- Turn the focus mode dial while holding down the focus mode dial lock release button.

### ② Place the subject within the AF area and press the shutter button halfway down.

The focus is locked.

- If it is difficult to focus on the desired subject, set [Focus Area] to [Center] or [Flexible Spot].



### ③ Keep pressing the shutter button halfway down, and place the subject back in the original position to re-compose the shot.



### ④ Press the shutter button down fully to take the picture.

#### Hint

- When the product cannot focus automatically, the focus indicator flashes and the beep does not sound. Either re-compose the shot or change the focus setting.

In [Continuous AF] mode,  lights up and the beep indicating that the focus has been achieved does not sound.

# Focusing

## Focus Mode

Selects the focus method to suit the movement of the subject.

**Turn the focus mode dial while pressing the focus mode dial lock release button and select the desired mode.**

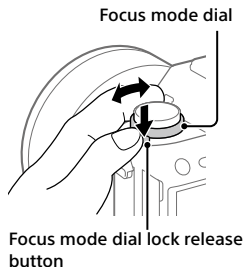

**AF-S (Single-shot AF):** The product locks the focus once focusing is complete. Use this when the subject is motionless.

**AF-C (Continuous AF):** The product continues to focus while the shutter button is pressed and held halfway down. Use this when the subject is in motion. In [Continuous AF] mode, there is no beep when the camera focuses.

**DMF (DMF):** You can make fine adjustments manually after performing auto focusing, letting you focus on a subject more quickly than when using the manual focus from the beginning. This is convenient in situations such as macro shooting.

**MF (Manual Focus):** Adjusts the focus manually. If you cannot focus on the intended subject using auto focus, use manual focus.

## Focus indicator

- **(lit)**: The subject is in focus and the focus is locked.
- **(flashing)**: The subject is not in focus.
- ⦿ **(lit)**: The subject is in focus. The focus will be adjusted continuously according to the movements of the subject.
- ⦿ **(lit)**: Focusing is in progress.

## Subjects on which it is difficult to focus using auto focus

- Dark and distant subjects
- Subjects with poor contrast
- Subjects seen through glass
- Fast-moving subjects
- Reflective light or shiny surfaces
- Flashing light
- Back-lit subjects
- Continuously repetitive patterns, such as the facades of buildings
- Subjects in the focusing area with different focal distances

### Note

- When [Continuous AF] is set, the angle of view may change little by little while focusing. This does not affect the actual recorded images.
- Even if the focus mode dial is set to AF-S or DMF, the focus mode will switch to [Continuous AF] when shooting movies or when the mode dial is set to S&Q.

### Hint

- In [Continuous AF] mode, you can lock the focus by pressing and holding the button that has been assigned the [Focus Hold] function (page 170).











# Auto focus

## Focus Area

Selects the focusing area. Use this function when it is difficult to focus properly in the auto focus mode.

**MENU** →  1 (Camera Settings 1) → **[Focus Area]** → **desired setting.**

-  **Wide:** Focuses on a subject covering the whole range of the screen automatically. When you press the shutter button halfway down in the still image shooting mode, a green frame is displayed around the area that is in focus.
-  **Zone:** Select a zone on the monitor on which to focus, and the product will automatically select a focus area.
-  **Center:** Focuses automatically on a subject in the center of the image. Use together with the focus-lock function to create the composition you want.
-  **Flexible Spot:** Allows you to move the focusing frame to a desired point on the screen and focus on an extremely small subject in a narrow area.
-  **Expand Flexible Spot:** If the product cannot focus on a single selected point, it uses focus points around the flexible spot as a secondary priority area for focusing.
-     **Lock-on AF:** When the shutter button is pressed and held halfway down, the product tracks the subject within the selected autofocus area. This setting is available only when the [Focus Mode] is set to [Continuous AF]. Point the cursor at [Lock-on AF] on the [Focus Area] setting screen, and then adjust the desired area to start tracking using the left/right sides of the control wheel. You can also move the tracking start area to the desired point by designating the area as a zone, flexible spot or expand flexible spot.

## Examples of the focusing frame display

The focusing frame differs as follows depending on the shooting mode.

### When focusing with the contrast AF or phase detection AF

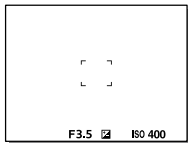

### When focusing with the phase detection AF

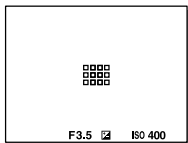

- When you attach an A-mount lens with a Mount Adaptor (LA-EA1 or LA-EA3) (sold separately) and [AF System] is set to [Phase Detection AF], the focusing frame for "When focusing with the phase detection AF" may be displayed.

### When focus is achieved automatically based on the whole range of the monitor

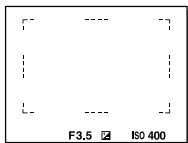

- When you use a zoom function other than the optical zoom, the [Focus Area] setting is disabled and the focusing frame is shown by the dotted line. The AF operates with priority on and around the center area.

## To move the focus area

- You can move the focus area in [Flexible Spot], [Expand Flexible Spot], or [Zone] by operating the multi-selector. If you assign [Focus Standard] to the center of the multi-selector beforehand, you can move the focusing frame back to the center of the monitor by pressing the center of the multi-selector.
- You can move the focusing frame quickly by touching and dragging it on the monitor. Set [Touch Operation] to [On] beforehand.

### Hint

- In the default settings, [Focus Area] is assigned to the C2 button.



### Note

- [Focus Area] is locked to [Wide] in the following situations:
  - [Intelligent Auto]
- The focus area may not light up during continuous shooting or when the shutter button is pressed all the way down at once.
- When the mode dial is set to  (Movie) or **S&Q**, or during movie shooting, [Lock-on AF] cannot be selected as the [Focus Area].

## Phase detection AF

When there are phase detection AF points within the auto focus area, the product uses the combined autofocus of the phase detection AF and contrast AF.

### Note

- Phase detection AF is available only when an applicable lens is attached. If you use a lens that does not support phase detection AF, you cannot use [ AF Track Sens], [ AF Track Sens] or [ AF drive speed]. Also, even if you use a previously purchased applicable lens, the phase detection AF might not function unless you update the lens.

## ■ Focus Standard

If you assign [Focus Standard] to the desired custom key, you can recall useful functions such as focusing on a subject in the center of the screen automatically in accordance with the focus area settings.

- ① **MENU →  2 (Camera Settings 2) → [Custom Key (Shoot.)] → desired button, then assign the [Focus Standard] function to the button.**
- ② **Press the key to which [Focus Standard] is assigned.**
  - What you can do by pressing the key varies depending on the settings for [Focus Area] and [Center Lock-on AF].

### **When [Focus Area] is set to [Zone], [Flexible Spot] or [Expand Flexible Spot]:**

Pressing the key moves the focusing frame back to the center.

### **When [Focus Area] is set to [Wide] or [Center]:**

- When [Center Lock-on AF] is set to [On], [Center Lock-on AF] is activated by pressing the key. The camera detects the subject positioned in the center of the screen and starts tracking by pressing the center of the control wheel while [Center Lock-on AF] is activated.
- When [Center Lock-on AF] is set to [Off], the camera focuses on the center point.

#### **Note**

- You cannot set the [Focus Standard] function to [Left Button], [Right Button] or [Down Button].

## Adjusting the focus area settings to the camera's orientation (horizontal/vertical) (📷 Swt. V/H AF Area)

You can set whether to switch the [Focus Area] and the position of the focusing frame according to the orientation of the camera (horizontal/vertical).

This function is useful when shooting scenes for which you have to change the camera position frequently, such as portraits or sports scene.

**MENU** → 📷1 (Camera Settings 1) → 📷 Swt. V/H AF Area → desired setting.

**Off:** Does not switch the [Focus Area] and the position of the focusing frame according to the orientation of the camera (horizontal/vertical).

**AF Point Only:** Switches the position of the focusing frame according to the orientation of the camera (horizontal/vertical). The [Focus Area] is fixed.

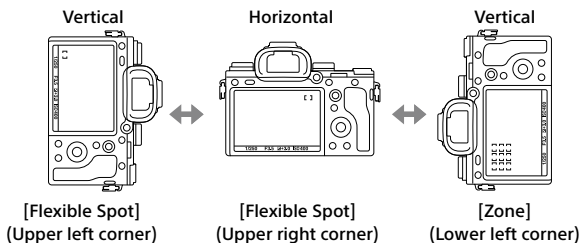

**AF Point + AF Area:** Switches both the [Focus Area] and the position of the focusing frame according to the orientation of the camera (horizontal/vertical).

### An example when [AF Point + AF Area] is selected



- Three camera orientations are detected: horizontal, vertical with the side of the shutter button facing up, and vertical with the side of the shutter button facing down.

## Note

- If the setting for  [Swt. V/H AF Area] is changed, the focus settings for each camera orientation will not be retained.
- The [Focus Area] and the position of the focusing frame will not change even when  [Swt. V/H AF Area] is set to [AF Point + AF Area] or [AF Point Only] in the following situations:
  - When the shooting mode is set to [Intelligent Auto], [Movie], or [S&Q Motion]
  - While the shutter button is pressed halfway down
  - During movie shooting
  - While using the digital zoom function
  - While the auto-focusing is activated
  - When [Focus Settings] are activated
  - During continuous shooting
  - During the countdown for the self-timer
  - When [Focus Magnifier] is activated
- When you shoot images right after the power is turned on and the camera is vertical, the first shot is taken with the horizontal focus setting or with the last focus setting.
- The orientation of the camera cannot be detected when the lens is facing up or down.

## AF/MF control

You can easily switch the focusing mode from auto to manual and vice versa while shooting without changing your holding position.

---

**MENU** →  **2 (Camera Settings 2)** → **[Custom Key (Shoot.)]** → **desired button** → **[AF/MF Control Hold]** or **[AF/MF Ctrl Toggle]**.

**AF/MF Control Hold:** Switches the focusing mode while the button is held down.

**AF/MF Ctrl Toggle:** Switches the focusing mode until the button is pressed again.

---

## Note





- You cannot set the [AF/MF Control Hold] function to [Left Button], [Right Button] or [Down Button] of the control wheel.

## AF On

You can focus without pressing the shutter button halfway down. The settings for the focus mode dial will be applied.

### Press the AF-ON (AF On) button while shooting in autofocus mode.

#### Hint

- Set [ AF w/ shutter] to [Off] when you do not want to perform auto focusing using the shutter button.
- Set [ AF w/ shutter], [ Pre-AF], and [ Eye-Start AF] to [Off] to focus at a specific shooting distance predicting the position of the subject.

## Eye AF

The camera focuses on the subject's eyes while you keep the button pressed.

- 1 MENU** →  **2 (Camera Settings 2)** → **[Custom Key (Shoot.)]** → **desired key, then assign the [Eye AF] function to the key.**
- 2 Point the camera at a person's face, and press the button to which you have assigned the [Eye AF] function.**
- 3 Press the shutter button while pressing the button.**

#### Hint

- When the camera focuses on the eyes, a detection frame is displayed over the eyes. If the focus mode is set to [Single-shot AF], the frame will disappear after a period of time.

## Note

- If the camera cannot detect a person's face, you cannot use [Eye AF].
- Depending on the circumstances, you cannot use [Eye AF] such as when [Focus Mode] is set to [Manual Focus].
- The [Eye AF] function may not function very well in the following situations:
  - When the person is wearing sunglasses.
  - When the front hair covers the person's eyes.
  - In low-light or back-lit conditions.
  - When the eyes are closed.
  - When the person is in the shade.
  - When the person is out of focus.
  - When the person is moving too much.
- If the person is moving too much, the detection frame may not display correctly over their eyes.
- When the mode dial is set to  (Movie) or S&Q, or during movie recording, [Eye AF] is unavailable.

## AF in Focus Mag.

You can focus on the subject more accurately using auto-focus by magnifying the area where you want to focus. While the magnified image is displayed, you can focus on a smaller area than the flexible spot.

---

**1** MENU →  1 (Camera Settings 1) →  AF in Focus Mag.] → [On].

---

**2** MENU →  1 (Camera Settings 1) → [Focus Magnifier].

---

**3** Magnify the image by pressing the center of the multi-selector, and then adjust the position by pressing the multi-selector up/down/left/right.

- The magnification scale changes each time you press the center.
- 

**4** Press the shutter button halfway down to focus.

- The focus will be achieved at point of + in the center of the screen.



---



## 5 Press the shutter button all the way down to shoot.

- The camera exits the magnified display after shooting.
- 

### Hint

- Use of a tripod is recommended to accurately identify the location you want to magnify.
- You can check the auto-focusing result by magnifying the displayed image. If you want to readjust the focus position, adjust the focus area on the magnified screen and then press the shutter button halfway down.

### Note

- If you enlarge an area at the edge of the screen, the camera may not be able to focus.
- The exposure and white balance cannot be adjusted while the displayed image is being magnified.
-  AF in Focus Mag.] is unavailable in the following situations:
  - During movie shooting
  - When [Focus Mode] is set to [Continuous AF].
  - When using a Mount Adaptor (sold separately).
- While the displayed image is being magnified, the following functions are unavailable:
  - [Eye AF]
  - [Center Lock-on AF]
  -  Eye-Start AF]
  -  Pre-AF]
  - [Face Detection]

## Center Lock-on AF

When you press the center of the control wheel, the camera detects the subject positioned in the center of the screen and continues to track the subject.

- 
- 1 **MENU** →  1 (Camera Settings 1) → [Center Lock-on AF] → [On].

---

## 2 Align the target frame over the subject and press the center of the control wheel.

- Press the center again to stop tracking.

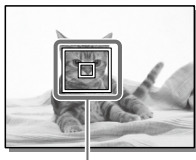

Target frame

---

## 3 Press the shutter button fully down to shoot the image.

---

### Hint

- If you assign the [Focus Standard] function to the desired key using [Custom Key (Shoot.)], you can activate [Center Lock-on AF] by pressing the key when [Center Lock-on AF] is set to [On] and [Focus Area] is set to [Wide] or [Center]. You can also detect the subject again by pressing the key to which [Focus Standard] is assigned.
- You can select the subject to be tracked by touch operation when shooting using the monitor. Set [Touch Operation] to [On].



### Note

- The [Center Lock-on AF] function may not function very well in the following situations:
  - The subject is moving too quickly.
  - The subject is too small, or too large.
  - The contrast between the subject and the background is poor.
  - It is dark.
  - The ambient light changes.
- Lock-on AF does not work in the following situations:
  - When shooting in Manual Focus mode.
  - When using the digital zoom
  - When [Record Setting] is set to [120p]/[100p].
  - When [S&Q] Frame Rate is set to [120fps]/[100fps].

## Registering the current focus area ( AF Area Regist.)

You can move the focusing frame to a preassigned position temporarily using a custom key. This function is useful when shooting scenes in which the subject's movements are predictable; for example, sports scenes. With this function, you can switch the focus area quickly according to the situation.

### How to register a focus area

- ① **MENU** → 1 (Camera Settings 1) → [ AF Area Regist.] → [On].
- ② Set the focus area to the desired position and then hold down the Fn (Function) button.



### How to call up the registered focus area

- ① **MENU** → 2 (Camera Settings 2) → [Custom Key (Shoot.)] → desired key, then select [Regist. AF Area hold].
- ② Set the camera to the shooting mode, hold down the key to which [Regist. AF Area hold] has been assigned and then press the shutter button to shoot images.

#### Hint

- When a focusing frame is registered using [ AF Area Regist.], the registered focusing frame flashes on the monitor.
- If you assign [Regist AF Area toggle] to a custom key, you can use the registered focusing frame without holding down the key.
- If [Reg. AF Area + AF On] is assigned to a custom key, auto focusing using the registered focusing frame is performed when the key is pressed.

## Note

- A focus area cannot be registered in the following situations:
  - The mode dial is set to either  (Movie) or **S&Q**
  - While [Touch Focus] is being performed
  - While using the digital zoom function
  - While [Lock-on AF] is being performed
  - While focusing
  - While performing focus lock
- You cannot call up the registered focus area in the following situations:
  - The mode dial is set to either **AUTO** (Auto Mode),  (Movie) or **S&Q**
- When [ AF Area Regist.] is set to [On], the [Lock Operation Parts] setting is locked to [Unlock].

## Pre-AF

The product automatically adjusts focus before you press the shutter button halfway down.

---

**MENU** →  1 (Camera Settings 1) → [ Pre-AF] → **desired setting.**

**On:** Adjusts focus before you press the shutter button halfway down.

**Off:** Does not adjust focus before you press the shutter button halfway down.

---

## Note

- [ Pre-AF] is available only when an E-mount lens is mounted.

## Priority Set in AF-S

Sets whether to release the shutter even if the subject is not in focus when [Focus Mode] is set to [Single-shot AF] or [DMF] and the subject is remaining still.

---

**MENU** → 1 (Camera Settings 1) → [Priority Set in AF-S] → **desired setting.**

**AF:** Prioritizes focusing. The shutter will not be released until the subject is in focus.

**Release:** Prioritizes the shutter's release. The shutter will be released even if the subject is out of focus.

**Balanced Emphasis:** Shoots with a balanced emphasis on both focusing and shutter release.

---

## Priority Set in AF-C

Sets whether to release the shutter even if the subject is not in focus when the continuous AF is activated and the subject is in motion.

---

**MENU** → 1 (Camera Settings 1) → [Priority Set in AF-C] → **desired setting.**

**AF:** Prioritizes focusing. The shutter will not be released until the subject is in focus.

**Release:** Prioritizes the shutter's release. The shutter will be released even if the subject is out of focus.

**Balanced Emphasis:** Shoots with a balanced emphasis on both focusing and shutter release.

---

## AF Illuminator

The AF illuminator supplies fill light to focus more easily on a subject in dark surroundings. In the time between pressing the shutter button halfway down and locking the focus, the red AF illuminator lights up to allow the camera to focus easily.

---

**MENU** →  **1 (Camera Settings 1)** → [ **AF Illuminator**] → **desired setting.**

**Auto:** The AF illuminator lights up automatically in dark surroundings.

**Off:** Does not use the AF illuminator.

---

### Note

- You cannot use [ AF Illuminator] in the following situations:
  - When the shooting mode is set to either [Movie] or [S&Q Motion].
  - When the focus mode is set to [Continuous AF].
  - When [Focus Magnifier] is activated (page 71).
  - When a Mount Adaptor is attached.
- The AF illuminator emits a very bright light. Although there is no health hazard, do not look directly into the AF illuminator at close range.

## AF Micro Adj.

Allows you to adjust the auto-focusing position and register an adjusted value for each lens when using A-mount lenses with an LA-EA2 or LA-EA4 Mount Adaptor (sold separately).

Use this function only when adjustments are needed. Note that the auto focus function may not be performed at a proper position when using this adjustment.

---

**1 MENU** → 1 (Camera Settings 1) → [AF Micro Adj.].

---

**2 Select [AF Adjustment Set.]** → [On].

---

**3 [amount]** → desired value.

- The larger the value you select, the farther the autofocused position will be from the product. The smaller the value you select, the closer the autofocused position will be to the product.
- 

### Hint

- It is recommended that you adjust the position under actual shooting conditions. Set [Focus Area] to [Flexible Spot] and use a bright subject with high contrast when you adjust.



### Note

- When you attach a lens for which you have already registered a value, the registered value appears on the screen. [±0] appears for lenses for which a value has not yet been registered.
- If [-] is displayed as the value, then a total of 30 lenses have been registered and no new lens can be registered. To register a new lens, attach a lens for which the registration can be erased, and set its value to [±0], or reset the values of all the lenses using [Clear].
- The [AF Micro Adj.] supports Sony, Minolta, or Konica-Minolta lenses. If you perform [AF Micro Adj.] with lenses other than the supported lenses, the registered settings for the supported lenses may be affected. Do not perform [AF Micro Adj.] with an unsupported lens.
- You cannot set [AF Micro Adj.] individually for a Sony, Minolta, and Konica-Minolta lens of the same specification.

## AF System

Sets the focus detection system (Phase Detection AF/Contrast AF) when you attach an A-mount lens using an LA-EA1/LA-EA3 Mount Adaptor (sold separately).

---



**MENU** →  1 (Camera Settings 1) → [ AF System] → **desired setting.**

**Phase Detection AF:** Focuses with Phase Detection AF. The focusing speed is very fast.

**Contrast AF:** Always focuses with Contrast AF. The focusing speed is slower. Use when you cannot focus with [Phase Detection AF].

---

### Note

- When [ AF System] is set to [Contrast AF], [Continuous AF] under [Focus Mode] is unavailable.
- The following functions are unavailable when [ AF System] is set to [Phase Detection AF]:
  - [Zone], [Expand Flexible Spot], and [Lock-on AF] in [Focus Area]
  - [Eye AF]
- When [ AF System] is set to [Phase Detection AF], [Priority Set in AF-S] will temporarily switch to [AF] even if it is set to [Balanced Emphasis].



# Manual Focus

When it is difficult to focus properly in the autofocus mode, you can adjust the focus manually.

- 1 Turn the focus mode dial while pressing the focus mode dial lock release button and select MF.**

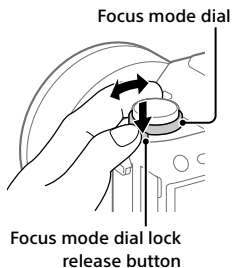

- 2 Rotate the focusing ring to achieve sharp focus.**

- When you rotate the focusing ring, the focus distance is displayed on the screen. The focus distance is not displayed when the Mount Adaptor (sold separately) is attached.

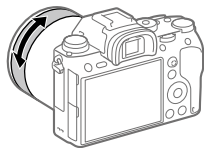

- 3 Press the shutter button fully down to shoot an image.**

## Note

- When you use the viewfinder, adjust the diopter level to obtain the correct focus on the viewfinder (page 25).

## Direct manual focus (DMF)

You can make fine adjustments manually after performing auto focusing, letting you focus on a subject more quickly than when using the manual focus from the beginning. This is convenient in situations such as macro shooting.

- 1 Turn the focus mode dial while pressing the focus mode dial lock release button and select DMF.**

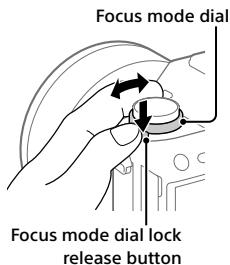

- 2 Press the shutter button halfway down to focus automatically.**

- 3 Keep the shutter button pressed halfway down, and then rotate the focusing ring to achieve a sharper focus.**

- When you rotate the focusing ring, the focus distance is displayed on the screen. The focus distance is not displayed when the Mount Adaptor (sold separately) is attached.

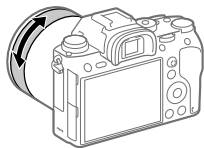

- 4 Press the shutter button fully down to shoot an image.**



## Focus Magnifier

You can check the focus by enlarging the image before shooting. Unlike with  MF Assist], you can magnify the image without operating the focus ring.

---







**1 MENU** → 1 (Camera Settings 1) → [Focus Magnifier].

**2 Press the center of the multi-selector to enlarge the image and select the area you want to enlarge by pressing the multi-selector up/down/left/right.**

- Each time you press the center, the magnification scale will change.
- You can set the initial magnification by selecting MENU → 1 (Camera Settings 1) →  Initial Focus Mag.].

---

**3 Confirm the focus.**

- Press the  (Delete) button to bring the magnified position into the center of an image.
- When the focus mode is [Manual Focus], you can adjust the focus while an image is magnified. If  AF in Focus Mag.] is set to [Off], the [Focus Magnifier] function is canceled when the shutter button is pressed halfway down.
- When the shutter button is pressed halfway down while an image is magnified during the auto-focusing, different functions are performed depending on the  AF in Focus Mag.] setting.
  - When  AF in Focus Mag.] is set to [On]:  
Auto-focusing is performed again.
  - When  AF in Focus Mag.] is set to [Off]:  
The [Focus Magnifier] function is canceled.
- You can set how long the image is to be shown magnified by selecting MENU → 1 (Camera Settings 1) → [Focus Magnif. Time].

---

**4 Press the shutter button fully down to shoot the image.**

---

## To use the focus magnifier function by touch operation

You can magnify the image and adjust the focus by touching the monitor. Set [Touch Operation] to [On] beforehand.

When the focus mode is [Manual Focus], you can perform [Focus Magnifier] by double-tapping the area to focus on.

### Hint

- While using the focus magnifier function, you can move the magnified area by dragging it on the touch panel.
- To exit the focus magnifier function, double-tap the monitor again. When [AF in Focus Mag.] is set to [Off], the focus magnifier function is ended by pressing the shutter button halfway down.

## MF Assist

Enlarges the image on the screen automatically to make manual focusing easier. This works in Manual Focus or Direct Manual Focus shooting.

---

**1 MENU** →  (Camera Settings 1) →  MF Assist → [On].

---



## **2 Turn the focus ring to adjust the focus.**

- The image is enlarged. You can magnify images further by pressing the center of the control wheel.

### Hint

- You can set how long the image is to be shown magnified by selecting MENU →  (Camera Settings 1) → [Focus Magnif. Time].

### Note

- You cannot use  MF Assist] when shooting movies. Use the [Focus Magnifier] function instead.
-  MF Assist] is not available when a Mount Adaptor is attached. Use the [Focus Magnifier] function instead.

## Peaking Level

Enhances the outline of in-focus ranges using a specific color in Manual Focus or Direct Manual Focus shooting.

---

**MENU** →  **1 (Camera Settings 1)** → **[Peaking Level]** → **desired setting.**

**High:** Sets the peaking level to high.

**Mid:** Sets the peaking level to middle.

**Low:** Sets the peaking level to low.

**Off:** Does not use the peaking function.

---

### Note



- Since the product recognizes sharp areas as in focus, the effect of peaking differs, depending on the subject and lens.
- The outline of in-focus ranges is not enhanced on devices connected via HDMI.

# Shutter setting

## Shutter Type

You can set whether to shoot with a mechanical shutter or an electronic shutter.

---

**MENU** →  2 (Camera Settings 2) →  Shutter Type] → **desired setting.**

**Auto:** The shutter type is automatically switched based on the shooting conditions and shutter speed.

**Mechanical Shut.:** Shoot with the mechanical shutter only.





**Electronic Shut.:** Shoot with the electronic shutter only.

---

### Hint

- In the following situations, set the [ Shutter Type] to [Auto] or [Electronic Shut.].
  - When shooting with a high-speed shutter in a bright environment such as outside in bright sunlight, the beach, or snowy mountains.
  - When you want to increase the speed of continuous shooting.

### Note

- In rare cases, the shutter sound may be produced when the power is turned off even if the [ Shutter Type] is set to [Electronic Shut.]. However, this is not a malfunction.
- In the following situations, the mechanical shutter will be activated even if the [ Shutter Type] is set to [Electronic Shut.].
  - When capturing a basic white color in [Custom Setup] for [White Balance]
  - [Face Registration]
- The following functions are unavailable when the [ Shutter Type] is set to [Electronic Shut.].
  - Flash shooting
  -  Long Exposure NR
  - Bulb shooting



## Using the electronic shutter

Using the electronic shutter lets you perform various kinds of shooting that are difficult to achieve using the mechanical shutter, such as shooting without sounds or shaking, shooting with a super-fast shutter, and blackout-free shooting\*.

\* During blackout-free shooting, the screen does not black out or drop frames and you can keep looking at the subject through the viewfinder or monitor while shooting images.

## Shutter types and camera performance

The camera's shutter speed range, shutter sound, occurrence of blackout, and availability of the flash for each setting are as follows:

	Shutter Type		
	 Auto	 Mechanical Shut.	 Electronic Shut.
<b>Shutter speed</b>	Single shooting: BULB – 1/32000 <sup>*1*2</sup> Continuous shooting: 1/8 – 1/32000 <sup>*1*2</sup>	Single shooting: BULB – 1/8000 Continuous shooting: 30 – 1/8000	Single shooting: 30 – 1/32000 <sup>*1*2</sup> Continuous shooting: 1/8 – 1/32000 <sup>*1*2</sup>
<b>Shutter sound</b>	Single shooting: Mechanical shutter sound Continuous shooting: Electronic shutter sound	Mechanical shutter sound	Electronic shutter sound
<b>Blackout</b>	Single shooting: Occurs Continuous shooting: Blackout-free <sup>*3</sup>	Occurs	Blackout-free <sup>*3</sup>
<b>Flash</b>	Available	Available	Unavailable



\*1 The maximum shutter speed is 1/16000 second when the shooting mode is not set to S (Shutter Priority) or M (Manual Exposure), or during bracket shooting with a setting other than [WB bracket] or [DRO Bracket].

\*2 The next value after 1/16000 second is 1/32000 second when the shooting mode is set to S (Shutter Priority) or M (Manual Exposure).

\*3 When [Shoot. Start Disp.] is set to [On], blackout occurs only when the first image is shot (page 78).





## ■ Advanced shooting using the electronic shutter: Shooting without shutter sound

You can use the electronic shutter to shoot without shutter sound.

- ① **MENU** →  2 (Camera Settings 2) →  Shutter Type] → [Electronic Shut.].
  - Select [Electronic Shut.] or [Auto] for continuous shooting.
- ② **MENU** →  2 (Camera Settings 2) → [Audio signals] → [Off] or [On: other than e-shut].

## ■ Advanced shooting using the electronic shutter: Blackout-free continuous shooting

You can use the electronic shutter to perform continuous shooting with focus and exposure tracking, without the screen blacking out.

- ① **MENU** →  2 (Camera Settings 2) →  Shutter Type] → [Auto] or [Electronic Shut.].
- ② Turn the mode dial and select **P (Program Auto)**, **A (Aperture Priority)**, **S (Shutter Priority)**, or **M (Manual Exposure)**, then set the shutter speed and aperture value. (For example: shutter speed of 1/250 second and aperture value of F2.8)
  - The product will not adjust the exposure in manual exposure mode when [ISO] is set to other than [ISO AUTO].
- ③ Turn the drive mode dial and select  H (Continuous Shooting: Hi),  M (Continuous Shooting: Mid), or  L (Continuous Shooting: Lo).
- ④ Turn the focus mode dial and select **AF-C (Continuous AF)**, then start shooting images.



**Hint**

- If you want to display the timing of shooting on the screen during blackout-free shooting, adjust the setting using MENU →  2 (Camera Settings 2) → [Shoot. Timing Disp.].
- To take advantage of the performance of the camera, we recommend that you use a UHS-II memory card. When using a UHS-II memory card, insert it into the memory card slot 1.

**Note**

- When shooting without the shutter sound, do so on your own responsibility, with sufficient consideration to the privacy and portrait rights of the subject.
- Even if you set the camera to shoot without the shutter sound, it will not be completely silent.
- Even if you set the camera to shoot without the shutter sound, the aperture and focus will make sounds.
- If you set [Audio signals] to [Off], the camera will not beep when the subject comes into focus or when the self-timer is in operation.
- During blackout-free shooting, the slower the shutter speed, the lower the refresh rate of the screen. If you want the screen display to be smooth in order to track the subject, set a shutter speed faster than 1/125 second.
- The electronic shutter operates differently when a Mount Adaptor is attached to the camera.

**Displaying the release timing (Shoot. Timing Disp.)**

Sets the method for displaying the shutter release timing on the screen during blackout-free shooting.

**MENU** →  2 (Camera Settings 2) → [Shoot. Timing Disp.] → **desired setting.**

**On: Type 1/On: Type 2:** Displays a frame around the focusing frame.

**On: Type 3/On: Type 4:** Displays  in the four corners of the screen.

**Off:** Does not display the shutter release timing during blackout-free shooting.

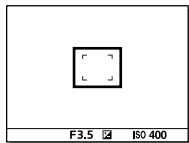

[On: Type 1]/[On: Type 2] (Example)

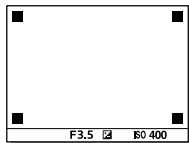

[On: Type 3]/[On: Type 4]

## Shoot. Start Disp.

Sets whether to let the screen black out when shooting the first image during blackout-free shooting.

---

**MENU** →  **2 (Camera Settings 2)** → **[Shoot. Start Disp.]** → **desired setting.**

**On:** The screen blacks out when shooting the first image during blackout-free shooting.

**Off:** The screen does not black out when shooting the first image during blackout-free shooting.

---

## e-Front Curtain Shut.

The electronic front curtain shutter function shortens the time lag between when the shutter button is pressed and the shutter is released. You can use [e-Front Curtain Shut.] when [ Shutter Type] is set to [Mechanical Shut.].

---

**MENU** →  **2 (Camera Settings 2)** → **[e-Front Curtain Shut.]** → **desired setting.**

**On:** Uses the electronic front curtain shutter function.

**Off:** Does not use the electronic front curtain shutter function.

---

### Note

- When you shoot at high shutter speeds with a large diameter lens attached, a defocused circle may get cut because of the shutter mechanism. In such cases, set this function to [Off].
- When a lens made by another manufacturer (including a Minolta/Konica-Minolta lens) is used, set this function to [Off]. If you set this function to [On], the correct exposure will not be set or the image brightness will be uneven.
- When you shoot at high shutter speeds, the image brightness may become uneven depending on the shooting environment. In such cases, set [e-Front Curtain Shut.] to [Off].

# Shooting with drive modes (continuous shooting/self-timer)

Select the appropriate mode for the subject, such as single shooting, continuous shooting or bracketing shooting.

## Select the desired drive mode by turning the drive mode dial.

- Turn the drive mode dial while holding down the drive mode dial lock release button.

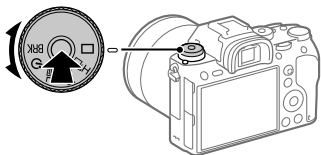

**Single Shooting:** Normal shooting mode.

H  M  L **Cont. Shooting:** Shoots images continuously while you press and hold down the shutter button.

**Self-timer:** Shoots an image using the self-timer after a designated number of seconds have elapsed since the shutter button was pressed.

**BRK Bracket:** Shoots images using the bracketing function. The type of bracketing function can be set by selecting MENU → 1 (Camera Settings 1) → [Bracket Settings] → [Bracket Type].

## Continuous shooting

Shoots images continuously while you press and hold down the shutter button.

### Turn the drive mode dial and select the desired mode.

- Turn the drive mode dial while pressing the drive mode dial lock release button.

H **Continuous Shooting: Hi** /  M **Continuous Shooting: Mid** /  L **Continuous Shooting: Lo**

	 Shutter Type	
	Mechanical Shut.	Auto/Electronic Shut.
<b>Continuous Shooting: Hi</b>	5 images per second at maximum* <sup>1</sup>	20 images per second at maximum * <sup>1</sup> * <sup>2</sup> * <sup>3</sup>
<b>Continuous Shooting: Mid</b>	5 images per second at maximum* <sup>1</sup>	10 images per second at maximum* <sup>1</sup>
<b>Continuous Shooting: Lo</b>	2.5 images per second at maximum	5 images per second at maximum* <sup>1</sup>

\*<sup>1</sup> When the F-value is greater than F11, the focus is locked to the setting in the first shot.

\*<sup>2</sup> When the Focus Mode is set to AF-C (Continuous AF), the speed of continuous shooting varies depending on the attached lens. For details, check the support page on compatible lenses.

\*<sup>3</sup> During uncompressed RAW shooting, 12 images are shot per second at maximum.

#### Hint

- To continuously adjust the focus and exposure during continuous shooting, set as follows:
  - [Focus Mode]: [Continuous AF]
  - [ AEL w/ shutter]: [Off] or [Auto]

#### Note

- Continuous shooting is unavailable in the following situations:
  - [Picture Effect] is set to [Rich-tone Mono.].
  - [DRO/Auto HDR] is set to [Auto HDR].

## ■ Displaying continuous shooting remaining time indicator (Cont. Shoot. Length)

Sets whether to display an indicator of the remaining time for which continuous shooting can be performed at the same shooting speed.

**MENU** →  2 (Camera Settings 2) → [Cont. Shoot. Length] → desired setting.

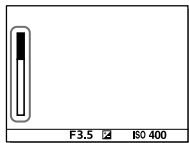

**Always Display:** Always displays the indicator when the drive mode is set to [Cont. Shooting].

**Shoot.-Only Display:** Displays the indicator only while continuous shooting is performed.

**Not Displayed:** Does not display the indicator.

### Hint

- When the internal camera memory for buffering is full, "SLOW" will be displayed and the continuous shooting speed will decrease.

## Self-timer

Shoots an image using the self-timer after a designated number of seconds have elapsed since the shutter button was pressed. Use the 5-second/10-second self-timer when you are going to be in the picture, and use the 2-second self-timer to reduce camera-shake caused by pressing the shutter button.

### 1 Select (Self-timer) by turning the drive mode dial.

- Turn the drive mode dial while holding down the drive mode dial lock release button.

### 2 MENU → 1 (Camera Settings 1) → [Self-timer Type] → [Self-timer (Single)] → desired mode.

The mode determines the number of seconds until a picture is taken after the shutter button is pressed.

- The setting screen for [Self-timer Type] can be displayed by pressing the Fn button.

 10 Self-timer (Single): 10 Sec



 5 Self-timer (Single): 5 Sec

 2 Self-timer (Single): 2 Sec

### 3 Adjust the focus and shoot the image.

The self-timer lamp flashes, a beep sounds, and a picture is taken after the designated number of seconds have elapsed.

#### Hint

- Press the shutter button again to stop the count of the self-timer.
- Select a drive mode other than  (Self-timer) by turning the drive mode dial to cancel the self-timer.
- Set [Audio signals] to [Off] to mute the beep sound during self-timer counting.
- To use the self-timer in bracket mode, select BRK (Bracket) by turning the drive mode dial, then select MENU →  1 (Camera Settings 1) → [Bracket Settings] → [Selftimer during Brkt].

## Self-timer (Cont)

Shoots a designated number of images using the self-timer after a designated number of seconds have elapsed since the shutter button was pressed. You can choose the best from multiple shots.

### 1 Select (Self-timer) by turning the drive mode dial.

- Turn the drive mode dial while holding down the drive mode dial lock release button.

### 2 MENU → 1 (Camera Settings 1) → [Self-timer Type] → [Self-timer (Cont)] → desired mode.

For example, three images are shot when 10 seconds have elapsed after the shutter button is pressed when [Self-timer (Cont.): 10 Sec. 3 Img.] is selected.

- The setting screen for [Self-timer Type] can be displayed by pressing the Fn button.

 **Self-timer (Cont.): 10 Sec. 3 Img.**

 **Self-timer (Cont.): 10 Sec. 5 Img.**

 **Self-timer (Cont.): 5 Sec. 3 Img.**

 **Self-timer (Cont.): 5 Sec. 5 Img.**

 **Self-timer (Cont.): 2 Sec. 3 Img.**

 **Self-timer (Cont.): 2 Sec. 5 Img.**

### 3 Adjust the focus and shoot the image.

The self-timer lamp flashes, a beep sounds, and pictures are taken after the designated number of seconds has elapsed. The designated number of pictures are taken continuously.

#### Hint

- Press the shutter button again to stop the count of the self-timer.
- Select a drive mode other than  (Self-timer) by turning the drive mode dial to cancel the self-timer.

## Cont. Bracket

Shoots multiple images while automatically shifting the exposure from base to darker and then to lighter (bracket shooting). You can select an image that suits your purpose after recording.

---

### 1 Select BRK (Bracket) by turning the drive mode dial.

- Turn the drive mode dial while holding down the drive mode dial lock release button.
- 

### 2 MENU → 1 (Camera Settings 1) → [Bracket Settings] → [Bracket Type] → [Cont. Bracket] → desired mode.

For example, the camera shoots a total of three images continuously with an exposure value shifted by plus or minus 0.3 EV when [Cont. Bracket: 0.3EV 3 Image] is selected.

- The setting screen for [Bracket Type] can be displayed by pressing the Fn button.
- 

### 3 Adjust the focus and shoot the image.

- The base exposure is set at the first shot.
  - Keep pressing and holding the shutter button until bracket shooting is finished.
- 

#### Note

- The last shot is shown on the auto review.
- When [ISO AUTO] is selected in [Manual Exposure] mode, the exposure is changed by adjusting the ISO value. If a setting other than [ISO AUTO] is selected, the exposure is changed by adjusting the shutter speed.
- When you adjust the exposure, the exposure is shifted based on the compensated value.
- Bracket shooting is unavailable in the following shooting modes:
  - [Intelligent Auto]
- When the flash is used, the product performs flash bracket shooting, which shifts the amount of flash light even if [Cont. Bracket] is selected. Press the shutter button for each image.



## Single Bracket

Shoots multiple images while automatically shifting the exposure from base to darker and then to lighter (bracket shooting). You can select the image that suits your purpose after recording.

Since a single picture is taken each time you press the shutter button, you can adjust the focus or the composition for each shot.

---

### 1 Select BRK (Bracket) by turning the drive mode dial.

- Turn the drive mode dial while holding down the drive mode dial lock release button.

---

### 2 MENU → 1 (Camera Settings 1) → [Bracket Settings] → [Bracket Type] → [Single Bracket] → desired mode.

For example, three images are shot one by one with an exposure value shifted by plus or minus 0.3 EV when [Single Bracket: 0.3EV 3 Image] is selected.

- The setting screen for [Bracket Type] can be displayed by pressing the Fn button.

---

### 3 Adjust the focus and shoot the image.

- Press the shutter button for each image.

#### Note

- When [ISO AUTO] is selected in [Manual Exposure] mode, the exposure is changed by adjusting the ISO value. If a setting other than [ISO AUTO] is selected, the exposure is changed by adjusting the shutter speed.
- When you adjust the exposure, the exposure is shifted based on the compensated value.
- Bracket shooting is unavailable in the following situations:
  - [Intelligent Auto]

## Indicator during bracket shooting

	Ambient light* bracketing 3 images shifted by 0.3 EV steps Exposure compensation $\pm 0.0$ EV	Flash bracketing 3 images shifted by 0.7 EV steps Flash compensation $-1.0$ EV
<b>Viewfinder</b>		No indicator is displayed.
<b>Monitor (Display All Info. or Histogram)</b>		
<b>Monitor (For viewfinder)</b>		
	(Upper indicator)	(Lower indicator)

\* Ambient light: A generic term for non-flash light including natural light, electric bulb and fluorescent lighting. Whereas the flash light blinks for a moment, ambient light is constant, so this kind of light is called “ambient light.”

### Note

- During bracket shooting, guides equal to the number of images to be shot are displayed over/under the bracket indicator.
- When you start single bracket shooting, the guides will disappear one by one as the camera records images.

## WB bracket

Shoots a total of three images, each with different color tones according to the selected settings for white balance, color temperature and color filter.

### 1 Select BRK (Bracket) by turning the drive mode dial.

- Turn the drive mode dial while holding down the drive mode dial lock release button.

### 2 MENU → 1 (Camera Settings 1) → [Bracket Settings] → [Bracket Type] → [WB bracket] → desired mode.

- The setting screen for [Bracket Type] can be displayed by pressing the Fn button.

** White Balance Bracket: Lo:** Records a series of three images with small changes in the white balance (within the range of 10MK<sup>-1\*</sup>).

** White Balance Bracket: Hi:** Records a series of three images with large changes in the white balance (within the range of 20MK<sup>-1\*</sup>).

- \* MK<sup>-1</sup> is the unit that indicates the capability of color temperature conversion filters and indicates the same value as "mired."

### 3 Adjust the focus and shoot the image.

#### Note

- The last shot is shown on the auto review.

## DRO Bracket

You can record a total of three images, each at a different degree of D-Range Optimizer value.

### 1 Select BRK (Bracket) by turning the drive mode dial.

- Turn the drive mode dial while holding down the drive mode dial lock release button.

### 2 MENU → 1 (Camera Settings 1) → [Bracket Settings] → [Bracket Type] → [DRO Bracket] → desired mode.

- The setting screen for [Bracket Type] can be displayed by pressing the Fn button.



**DRO Bracket: Lo:** Records a series of three images with small changes in the D-Range Optimizer value (Lv 1, Lv 2, and Lv 3).



**DRO Bracket: Hi:** Records a series of three images with large changes in the D-Range Optimizer value (Lv 1, Lv 3, and Lv 5).

### 3 Adjust the focus and shoot the image.

#### Note

- The last shot is shown on the auto review.

## Bracket Settings

You can set the type of bracket or the self-timer in bracket shooting mode, and the shooting order for exposure bracketing or white balance bracketing.

① **Select BRK (Bracket) by turning the drive mode dial.**

- Turn the drive mode dial while holding down the drive mode dial lock release button.

② **MENU** →  **1 (Camera Settings 1)** → **[Bracket Settings]** → **desired setting.**

**Bracket Type:** Sets the type of bracket shooting.

(Cont. Bracket / Single Bracket / WB bracket / DRO Bracket)

**Selftimer during Brkt:** Sets whether to use the self-timer during bracket shooting. Also sets the number of seconds until the shutter is released if using the self-timer.

(OFF/2 Sec/5 Sec/10 Sec)

**Bracket order:** Sets the order of exposure bracketing and white balance bracketing.

(0 → - → + / - → 0 → +)

# Using touch function

## Touch Operation

Sets whether to activate or not the touch operation of the monitor.

---

**MENU** →  (Setup) → [Touch Operation] → **desired setting.**

**On:** Activates the touch operation.

**Off:** Deactivates the touch operation.

---

## Touch Focus

You can select a subject on which to focus using touch operations in the still image and movie recording modes.



---

**MENU** →  (Setup) → [Touch Operation] → [On].

---



## ■ Specifying the position where you want to focus in the still image mode

You can focus on the desired position by touching the monitor.

- ① **Select a [Focus Area] other than [Flexible Spot] or [Expand Flexible Spot].**
- ② **MENU** →  1 (Camera Settings 1) → [Center Lock-on AF] → [Off].
- ③ **Touch the monitor.**
  - Touch the subject to focus.
  - When the shutter button is pressed halfway down, the camera focuses on the focusing frame. Press the shutter button all the way down to shoot images.
  - To cancel focusing with touch operations, touch  or press the center of the control wheel.

## ■ Specifying the position where you want to focus in the movie recording mode (spot focus)

The camera will focus on the touched subject.

- ① Select a [Focus Area] other than [Flexible Spot] or [Expand Flexible Spot].
- ② MENU →  1 (Camera Settings 1) → [Center Lock-on AF] → [Off].
- ③ Touch the subject on which you want to focus before or during recording.
  - When you touch the subject, the focus mode temporarily switches to manual focus and the focus can be adjusted using the focus ring.
  - To cancel spot focus, touch  or press the center of the control wheel.

### Hint

- In addition to the touch focus function, touch operations such as the following are also available.
  - When [Focus Area] is set to [Flexible Spot] or [Expand Flexible Spot], the focusing frame can be moved using touch operations.
  - When the [Focus Mode] is set to [Manual Focus], the focus magnifier can be used by double-tapping the monitor.



### Note

- The touch focus function is not available in the following situations:
  - When using the viewfinder
  - When [Focus Mode] is set to [Manual Focus].
  - When using the digital zoom
  - When using the LA-EA2 or LA-EA4
  - When using the LA-EA1 or LA-EA3, and the shooting mode is set to [Movie]

# Selecting a still image size/image quality

## Image Size

The larger the image size, the more detail will be reproduced when the image is printed on large-format paper. The smaller the image size, the more images can be recorded.

**MENU** →  1 (Camera Settings 1) →  Image Size] → desired setting.

When [Aspect Ratio] is set to 3:2		When [Aspect Ratio] is set to 16:9	
<b>L: 24M</b>	6000×4000 pixels	<b>L: 20M</b>	6000×3376 pixels
<b>M: 10M</b>	3936×2624 pixels	<b>M: 8.7M</b>	3936×2216 pixels
<b>S: 6.0M</b>	3008×2000 pixels	<b>S: 5.1M</b>	3008×1688 pixels

When [APS-C/Super 35mm] is set to [On]



When [Aspect Ratio] is set to 3:2		When [Aspect Ratio] is set to 16:9	
<b>L: 10M</b>	3936×2624 pixels	<b>L: 8.7M</b>	3936×2216 pixels
<b>M: 6.0M</b>	3008×2000 pixels	<b>M: 5.1M</b>	3008×1688 pixels
<b>S: 2.6M</b>	1968×1312 pixels	<b>S: 2.2M</b>	1968×1112 pixels

### Note

- When  Quality] is set to [RAW] or [RAW & JPEG], the image size for RAW images corresponds to "L."





## Aspect Ratio

**MENU** → 1(Camera Settings 1) → [ Aspect Ratio] → desired setting.

**3:2:** Suitable for standard prints.

**16:9:** For viewing on a high-definition TV.

## Quality

**MENU** → 1(Camera Settings 1) → [ Quality] → desired setting.

**RAW:** File format: RAW

Digital processing is not performed on this file format. Select this format to process images on a computer for professional purposes.

- The image size is fixed to the maximum size. The image size is not displayed on the screen.

**RAW & JPEG:** File format: RAW + JPEG

A RAW image and a JPEG image are created at the same time. This is suitable when you need two image files, a JPEG for viewing, and a RAW for editing. The JPEG image quality is set to [Fine].

**Extra fine:** File format: JPEG

The image is compressed in the JPEG format and recorded using a higher quality than with [Fine].

**Fine:** File format: JPEG

The image is compressed in the JPEG format when recorded.

**Standard:** File format: JPEG

The image is compressed in the JPEG format when recorded. Since the compression rate of [Standard] is higher than that of [Fine], the file size of [Standard] is smaller than that of [Fine]. This will allow more files to be recorded on one memory card, but the image quality will be lower.

## About RAW images

- To open a RAW image file recorded with this camera, the software Image Data Converter is needed. With Image Data Converter, you can open a RAW image file, then convert it into a popular image format such as JPEG or TIFF, or readjust the white balance, saturation or contrast of the image.
- You cannot apply [Auto HDR] or [Picture Effect] functions with RAW images.
- RAW images recorded with this camera have a resolution of 14 bits per pixel. However, the resolution may be limited to 12 bits in the following shooting modes:
  - [📷 Long Exposure NR]
  - [BULB]
  - Continuous shooting
- You can set whether RAW images are compressed or uncompressed using [📷 RAW File Type].

### Note

- If you do not intend to edit the images on your computer, we recommend that you record in JPEG format.
- You cannot add DPOF (print order) registration marks to RAW images.

## APS-C/Super 35mm

Sets whether to record in APS-C-equivalent size for still images and in Super 35mm-equivalent size for movies. If you select [On] or [Auto], you can use an APS-C size dedicated lens on this product.

---

**MENU** →  **1 (Camera Settings 1)** → **[APS-C/Super 35mm]** → **desired setting.**

**On:** Records in either APS-C-equivalent size or Super 35mm-equivalent size.

**Auto:** Automatically sets the capture range depending on the lens.

**Off:** Always captures 35mm full-size image sensor pictures.

---

### Note

- When you attach an APS-C compatible lens and set [APS-C/Super 35mm] to [Off], shooting may fail.
- When you set [APS-C/Super 35mm] to [On], the angle of view will be the same as when shooting with an APS-C size image sensor.

# Selecting a shooting mode

## List of mode dial function

You can select the desired shooting mode by turning the mode dial.

- Turn the mode dial while pressing the mode dial lock release button in the center of the mode dial.

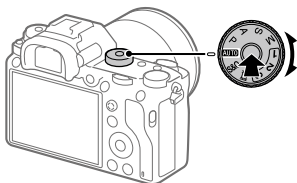

## Available functions

<b>i</b> (Intelligent Auto)	Allows you to shoot with automatic scene recognition.
<b>P</b> (Program Auto)	Allows you to shoot with the exposure adjusted automatically (both the shutter speed and the aperture value (F value)). Also you can select various settings using the menu.
<b>A</b> (Aperture Priority)	Allows you to adjust the aperture and shoot when you want to blur the background, etc.
<b>S</b> (Shutter Priority)	Allows you to shoot fast-moving subjects etc., by manually adjusting the shutter speed.
<b>M</b> (Manual Exposure)	Allows you to shoot still images with the desired exposure by adjusting the exposure (both the shutter speed and the aperture value (F value)).
<b>1/2/3</b> (Memory recall)	Allows you to shoot an image after recalling often-used modes or numeric settings registered in advance.
<b>Movie</b> (Movie)	Allows you to change the exposure mode for movie recording.
<b>S&amp;Q</b> (S&Q Motion)	Allows you to shoot slow-motion and quick-motion movies.

## **AUTO** (i📷 Intelligent Auto)

The camera shoots with automatic scene recognition.

### 1 Set the mode dial to **AUTO** (Auto Mode).

- The shooting mode will be set to **i📷** (Intelligent Auto).

### 2 Point the camera at the subject.

When the camera recognized the scene, the icon for the recognized scene appears on the screen.



### 3 Adjust the focus and shoot the image.

#### Note











- The product will not recognize the scene when you shoot images with zoom functions other than optical zoom.
- The product may not properly recognize the scene under certain shooting conditions.

## About Scene Recognition

Scene Recognition operates in [Intelligent Auto] mode. This function allows the product to automatically recognize the shooting conditions and shoot the image.

### Scene Recognition

When the product recognizes certain scenes, the following icons and guides are displayed on the first line:

 (Portrait),  (Infant),  (Night Portrait),  (Night Scene),  (Backlight Portrait),  (Backlight),  (Landscape),  (Macro),  (Spotlight),  (Low Light),  (Night Scene using a tripod)

#### Note

- When [Face Detection] is set to [Off], the [Portrait], [Backlight Portrait], [Night Portrait] and [Infant] scenes are not recognized.

## P Program Auto

Allows you to shoot with the exposure adjusted automatically (both the shutter speed and the aperture value).

You can set shooting functions such as [ISO].

---

**1 Set the mode dial to P (Program Auto).**

---

**2 Set the shooting functions to your desired settings.**

---

**3 Adjust the focus and shoot the subject.**

---

### Program Shift

When you are not using a flash, you can change the shutter speed and aperture (F-value) combination without changing the appropriate exposure set by the camera.

Turn the front/rear dial to select the aperture value and shutter speed combination.

- “P” on the screen changes to “P\*” when you turn the front/rear dial.
- To cancel program shift, set the shooting mode to other than [Program Auto], or turn off the camera.

#### Note

- According to the brightness of the environment, the program shift may not be used.
- Set the shooting mode to another one than “P” or turn off the power to cancel the setting you made.
- When the brightness changes, the aperture (F-value) and shutter speed also change while maintaining the shift amount.

## A Aperture Priority

You can shoot by adjusting the aperture and changing the range in focus, or by defocusing the background.

### 1 Set the mode dial to A (Aperture Priority).

### 2 Select the desired value by turning the front/rear dial.

- Smaller F-value: The subject is in focus, but objects in front of and beyond the subject are blurred.  
Larger F-value: The subject and its foreground and background are all in focus.
- If the aperture value you have set is not suitable for appropriate exposure, the shutter speed on the shooting screen will blink. If this happens, change the aperture value.

### 3 Adjust the focus and shoot the subject.

The shutter speed is automatically adjusted to obtain proper exposure.

#### Note

- The brightness of the image on the screen may differ from the actual image being shot.

## S Shutter Priority

You can express the movement of a moving subject in various ways by adjusting the shutter speed, for example, at the instant of the movement with high speed shutter, or as a trailing image with low speed shutter.

### 1 Set the mode dial to S (Shutter Priority).

### 2 Select the desired value by turning the front/rear dial.

- If proper exposure cannot be obtained after setup, the aperture value on the shooting screen blinks. If this happens, change the shutter speed.

---

### 3 Adjust the focus and shoot the subject.



The aperture is automatically adjusted to obtain proper exposure.

---

#### Hint

- Use a tripod to prevent camera-shake when you have selected a slow shutter speed.
- When you shoot indoor sports scenes, set the ISO sensitivity to a higher value.

#### Note

- The SteadyShot warning indicator does not appear in shutter speed priority mode.
- When [ Long Exposure NR] is set to [On] and the shutter speed is 1 second or longer with a [ Shutter Type] other than [Electronic Shut.] is set, noise reduction after shooting is performed for the same amount of time that the shutter was open. However, you cannot shoot any more while noise reduction is in progress.
- The brightness of the image on the screen may differ from the actual image being shot.

## M Manual Exposure

You can shoot with the desired exposure setting by adjusting both the shutter speed and aperture.

---

### 1 Set the mode dial to M (Manual Exposure).



---

## 2 Select the desired aperture value by turning the front dial.

### Select the desired shutter speed by turning the rear dial.

- You can change the setting of the front/rear dial using MENU →  2 (Camera Settings 2) → [Dial Setup].
- You can also set [ISO] to [ISO AUTO] in manual exposure mode. The ISO value automatically changes to achieve the appropriate exposure using the aperture value and shutter speed you have set.
- When [ISO] is set to [ISO AUTO], the ISO value indicator will blink if the value you have set is not suitable for appropriate exposure. If this happens, change the shutter speed or aperture value.
- When [ISO] is set to other than [ISO AUTO], use MM (Metered Manual)\* to check the exposure value.

**Toward +:** Images become brighter.

**Toward -:** Images become darker.

**0:** Appropriate exposure analyzed by the product.

\* Indicates under/over for appropriate exposure. It is displayed using a numerical value on the monitor and with a metering indicator on the viewfinder.

---

## 3 Adjust the focus and shoot the subject.

---

### Hint

- You can change the shutter speed and aperture (F-value) combination without changing the set exposure value by rotating the front/rear dial while pressing the AEL button. (Manual shift)

### Note

- The Metered Manual indicator does not appear when [ISO] is set to [ISO AUTO].
- When the amount of ambient light exceeds the metering range of the Metered Manual, the Metered Manual indicator flashes.
- The SteadyShot warning indicator does not appear in manual exposure mode.
- The brightness of the image on the screen may differ from the actual image being shot.

## M Bulb shooting

You can shoot a trailing image of the movement of a subject with long exposure.

Bulb shooting is suitable for shooting trails from stars or fireworks, etc.

---

**1 Set the mode dial to M (Manual Exposure).**

---

**2 Turn the rear dial clockwise until [BULB] is indicated.**

---

**3 Select the aperture value (F-value) using the front dial.**

---

**4 Press the shutter button halfway down to focus.**

---

**5 Press and hold the shutter button for the duration of the shooting.**



As long as the shutter button is pressed, the shutter remains open.

---



### Hint

- When shooting fireworks, etc., focus at infinity in manual focus mode. If you use a lens whose infinity point is unclear, adjust the focus on the fireworks in the area you want to focus on in advance.
- In order to perform bulb shooting without causing the image quality to deteriorate, we recommend that you start shooting while the camera is cool.
- Images shot in [BULB] mode tend to be blurry. We recommend that you use a tripod and a remote commander (sold separately) that has a shutter button lock function. Use a remote commander supporting connection via multi/micro USB jack.

**Note**

- The longer the exposure time, the more noise will be visible on the image.
- After shooting, noise reduction will be done for the same amount of time that the shutter was open. However, you cannot shoot any more while noise reduction is in progress.
- You cannot set the shutter speed to [BULB] in the following situations:
  - [Auto HDR]
  - [Picture Effect] is set to [Rich-tone Mono.]
  - When [Drive Mode] is set to the following:
    - [Cont. Shooting]
    - [Self-timer (Cont)]
    - [Cont. Bracket]
  - [ Shutter Type] is set to [Electronic Shut.]If you use the above functions when the shutter speed is set to [BULB], the shutter speed is temporarily set to 30 seconds.
- If you set [Drive Mode] to [Cont. Shooting] and [ Shutter Type] to [Auto] or [Electronic Shut.] when the shutter speed is set to [BULB], the shutter speed will be temporarily set to 1/8 seconds.

**  Recall**

Allows you to shoot an image after recalling often-used modes or camera settings registered with [  Memory] in advance.



**1 Set the mode dial to 1, 2, or 3 (Memory recall).****2 Press the center of the control wheel to confirm.**

- You can also recall registered modes or settings by selecting MENU →  1 (Camera Settings 1) → [  Recall].

## Hint

- To recall settings registered to the memory card, set the mode dial to 1, 2 or 3, then select the desired number by pressing the left/right side of the control wheel.
- If you recall settings registered to the memory card, the settings are recalled from the memory card in the slot specified in [Select Rec. Media]. You can confirm the memory card slot by selecting MENU →  (Setup) → [Select Rec. Media].
- Settings registered to a memory card using another camera of the same model name can be recalled with this camera.

## Note

- If you set [  Recall] after completing the shooting settings, the registered settings are given priority and the original settings may become invalid. Check the indicators on the screen before shooting.

## Movie: Exposure Mode

You can select the exposure mode for movie shooting.

### 1 Set the mode dial to (Movie).

### 2 MENU → (Camera Settings 2) → [ Exposure Mode] → desired setting.

 **P Program Auto:** Allows you to shoot with the exposure adjusted automatically (both the shutter speed and the aperture value).

 **A Aperture Priority:** Allows you to shoot after adjusting the aperture value manually.

 **S Shutter Priority:** Allows you to shoot after adjusting the shutter speed manually.

 **M Manual Exposure:** Allows you to shoot after adjusting the exposure (both the shutter speed and the aperture value) manually.

### 3 Press the **MOVIE (movie)** button to start recording.

- Press the **MOVIE (movie)** button again to stop recording.

## S&Q S&Q Motion: Exposure Mode

You can select the exposure mode for slow-motion/quick-motion shooting. You can change the setting and playback speed for slow-motion/quick-motion shooting with [ S&Q Settings] (page 147).

### 1 Set the mode dial to S&Q (S&Q Motion).

### 2 MENU → 2 (Camera Settings 2) → [ Exposure Mode] → desired setting.

 **P Program Auto:** Allows you to shoot with the exposure adjusted automatically (both the shutter speed and the aperture value).

 **A Aperture Priority:** Allows you to shoot after adjusting the aperture value manually.

 **S Shutter Priority:** Allows you to shoot after adjusting the shutter speed manually.

 **M Manual Exposure:** Allows you to shoot after adjusting the exposure (both the shutter speed and the aperture value) manually.

### 3 Press the MOVIE (movie) button to start recording.

- Press the MOVIE (movie) button again to stop recording.

# Controlling the exposure/metering modes

## Exposure Comp.

Normally, exposure is set automatically (auto exposure). Based on the exposure value set by auto exposure, you can make the entire image brighter or darker if you adjust [Exposure Comp.] to the plus side or minus side, respectively (exposure compensation).

### Turn the exposure compensation dial.

- **+ (over) side:** Images become brighter.
- **- (under) side:** Images become darker.
- You can adjust the exposure compensation value within the range of -3.0 EV to +3.0 EV.
- You can confirm the exposure compensation value that you set on the shooting screen.



Exposure compensation dial

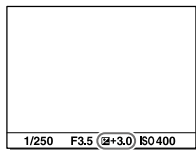

Monitor

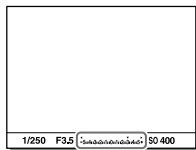

Viewfinder

## ■ To set the exposure compensation using the MENU

You can adjust the exposure compensation within a range of -5.0 EV to +5.0 EV when the exposure compensation dial is set to "0."

**MENU** →  **1 (Camera Settings 1)** → **[Exposure Comp.]** → **desired setting.**

### Note





- You cannot perform the exposure compensation in the following shooting modes:
  - [Intelligent Auto]
- When using [Manual Exposure], you can perform the exposure compensation only when [ISO] is set to [ISO AUTO].
- The settings of the exposure compensation dial will be prioritized over [Exposure Comp.] or [Dial Ev Comp] in MENU.
- Only a value between -3.0 EV and +3.0 EV with the equivalent image brightness appears on the screen when shooting. If you set an exposure compensation value outside this range, the image brightness on the screen will not be affected, but the value will be reflected in the recorded image.
- You can adjust the exposure compensation value within the range of -2.0 EV to +2.0 EV when recording movies.
- If you shoot a subject in extremely bright or dark conditions, or when you use the flash, you may not be able to get a satisfactory effect.
- When you set the exposure compensation dial to "0" from a setting other than "0," the exposure value switches to "0" regardless of the [Exposure Comp.] setting.

## Metering Mode

Selects the metering mode that sets which part of the screen to measure for determining the exposure.

---

**MENU** → 1 (Camera Settings 1) → [Metering Mode] → desired setting.

-  **Multi:** Measures light on each area after dividing the total area into multiple areas and determines the proper exposure of the entire screen (Multi-pattern metering).
  -  **Center:** Measures the average brightness of the entire screen, while emphasizing the central area of the screen (Center-weighted metering).
  -  **Spot:** Measures only the central area (Spot metering). This mode is suitable for measuring light on a specified part of the entire screen. The size of the metering circle can be selected from [Spot: Standard] and [Spot: Large]. The position of the metering circle depends the setting for [Spot Metering Point].
  -  **Entire Screen Avg.:** Measures the average brightness of the entire screen. The exposure will be stable even if the composition or the position of the subject changes.
  -  **Highlight:** Measures the brightness while emphasizing the highlighted area on the screen. This mode is suitable for shooting the subject while avoiding overexposure.
- 

### Hint

- When [Spot] is selected and [Focus Area] is set to either [Flexible Spot] or [Expand Flexible Spot] while [Spot Metering Point] is set to [Focus Point Link], the spot metering point can be coordinated with the focus area.
- When [Metering Mode] is set to [Highlight] and the [D-Range Opt.] or [Auto HDR] function is activated, the brightness and the contrast will be corrected automatically by dividing the image into small areas and analyzing the contrast of light and shadow. Make settings based on the shooting circumstances.



## Note

- [Metering Mode] is locked to [Multi] in the following shooting modes:
  - [Intelligent Auto]
  - Other zoom functions than the optical zoom
- In [Highlight] mode, the subject may be dark if a brighter part exists on the screen.

## Spot Metering Point

Sets whether to coordinate the spot metering position with the focus area when [Focus Area] is set to [Flexible Spot] or [Expand Flexible Spot].

**MENU** →  **1 (Camera Settings 1)** → **[Spot Metering Point]** → **desired setting.**

**Center:** The spot metering position does not coordinate with the focus area, but always meters brightness at the center.

**Focus Point Link:** The spot metering position coordinates with the focus area.

## Note

- When [Focus Area] is set to other than [Flexible Spot] or [Expand Flexible Spot], the spot metering position is locked to the center.
- When [Focus Area] is set to [Lock-on AF: Flexible Spot] or [Lock-on AF: Expand Flexible Spot], the spot metering position coordinates to the Lock-on AF start position, but does not coordinate with the tracking of the subject.

## AE lock

When the contrast between the subject and background is high, such as when shooting a backlit subject or a subject near a window, meter the light at a spot where the subject appears to have the appropriate brightness and lock the exposure before shooting. To reduce the brightness of the subject, meter the light at a spot brighter than the subject and lock the exposure of the entire screen. To make the subject brighter, meter the light at a spot darker than the subject and lock the exposure of the entire screen.

### 1 Adjust the focus on the spot at which the exposure is adjusted.

### 2 Press the AEL button.

The exposure is locked, and \* (AE lock) is displayed.

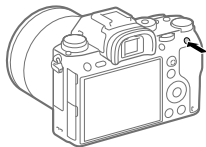

### 3 Keep pressing the AEL button and focus on the subject again, then shoot the picture.

- Keep holding the AEL button down while taking a shot if you want to continue shooting with the fixed exposure. Release the button to reset the exposure.

#### Hint

- If you select the MENU → 2 (Camera Settings 2) → [Custom Key (Shoot.)] → [AEL Button] → [AEL toggle], you can lock the exposure without holding down the button.

#### Note

- [ AEL hold] and [ AEL toggle] are not available when using zoom functions other than optical zoom.

## Zebra

The zebra pattern will appear over part of an image if the brightness level of that part meets the IRE level that you set. Use this zebra pattern as a guide to adjust the brightness.

---

**MENU** →  **2 (Camera Settings 2)** → **[Zebra]** → **desired setting**.

**Off:** Does not display the zebra pattern.

**70/75/80/85/90/95/100/100+/Custom 1/Custom 2:** Adjusts the brightness level.

---

### Hint

- You can register values to check the correct exposure or overexposure as well as the brightness level for [Zebra]. The settings for correct exposure confirmation and overexposure confirmation are registered to [Custom 1] and [Custom 2] respectively in the default settings.
- To check the correct exposure, set a standard value and the range for the brightness level. The zebra pattern will appear on areas that fall within the range you set.
- To check the overexposure, set a minimum value for the brightness level. The zebra pattern will appear over areas with a brightness level equal to or higher than the value you set.

### Note

- The zebra pattern is not displayed on devices connected via HDMI.

# Correcting brightness and contrast automatically

## D-Range Opt. (DRO)

By dividing the image into small areas, the product analyzes the contrast of light and shadow between the subject and the background, and creates an image with the optimal brightness and gradation.



**1** MENU →  1 (Camera Settings 1) → [DRO/Auto HDR] → [D-Range Opt.].

**2** Select the desired setting using the left/right sides of the control wheel.

 **D-Range Optimizer: Auto:** Corrects the brightness automatically.

 **D-Range Optimizer: Lv1 — D-Range Optimizer: Lv5:** Optimizes the gradation of a recorded image for each divided area. Select the optimization level from Lv1 (weak) to Lv5 (strong).

### Note

- In the following situations, [D-Range Opt.] is fixed to [Off]:
  - When [Picture Effect] is set to other than [Off]
- When  Record Setting] is set to [120p 100M], [100p 100M], [120p 60M], or [100p 60M], or when  Frame Rate] is set to [120fps]/[100fps], [DRO/Auto HDR] switches to [Off].
- When shooting with [D-Range Opt.], the image may be noisy. Select the proper level by checking the recorded image, especially when you enhance the effect.

## Auto HDR

Shoots three images using different exposures and combines the images with correct exposure, the bright parts of an underexposed image, and the dark parts of an overexposed image to create images with a greater range of gradation (High Dynamic Range). One image with proper exposure and one overlaid image are recorded.

---

**1** MENU →  1 (Camera Settings 1) → [DRO/Auto HDR] → [Auto HDR].

---

**2** Select the desired setting using the left/right sides of the control wheel.

 **Auto HDR: Exposure Diff. Auto:** Corrects the brightness automatically.

 **Auto HDR: Exposure Diff. 1.0EV — Auto HDR: Exposure Diff. 6.0EV:** Sets the exposure difference, based on the contrast of the subject. Select the optimization level from 1.0 EV (weak) to 6.0 EV (strong). For example, if you set the exposure value to 2.0 EV, three images will be composed with the following exposure levels: -1.0 EV, correct exposure and +1.0 EV.

---

### Hint

- The shutter is released three times for one shot. Be careful about the following:
  - Use this function when the subject is motionless or does not flash light.
  - Do not change the composition before shooting.

## Note

- This function is not available when the [🖼️ Quality] is [RAW] or [RAW & JPEG].
- [Auto HDR] is not available in the following shooting modes:
  - [Intelligent Auto]
- [Auto HDR] is not available in the following situations:
  - When [Picture Effect] is set to other than [Off].
- You cannot start the next shot until the capture process is completed after you shoot.
- You may not obtain the desired effect depending on the luminance difference of a subject and the shooting conditions.
- When the flash is used, this function has little effect.
- When the contrast of the scene is low or when product shake or subject blur occurs, you may not obtain good HDR images. **HDR** **!** will be displayed over the recorded image to inform you when the camera detects image blurring. Change the composition or re-shoot the image carefully to avoid image blur, as needed.

# Selecting the ISO sensitivity

Sensitivity to light is expressed by the ISO number (recommended exposure index). The larger the number, the higher the sensitivity.

## ISO (ISO) on the control wheel → select desired setting.

- You can also select MENU → 1 (Camera Settings 1) → [ISO].
- You can change the value by 1/3 EV steps by turning the front dial as well as by turning the control wheel. You can change the value by 1 EV steps by turning the rear dial.



**ISO AUTO:** Sets the ISO sensitivity automatically.

**ISO 50 – ISO 204800:** Sets the ISO sensitivity manually. Selecting a larger number increases the ISO sensitivity.

### Hint

- You can change the range of ISO sensitivity that is set automatically in [ISO AUTO] mode. Select [ISO AUTO] and press the right side of the control wheel, and set the desired values for [ISO AUTO Maximum] and [ISO AUTO Minimum].

### Note

- [ISO AUTO] is selected when using the following functions:
  - [Intelligent Auto]
- When the ISO sensitivity is set to a value lower than ISO 100, the range for recordable subject brightness (dynamic range) may decrease.
- The higher the ISO value, the more noise will appear on the images.
- The available ISO settings will differ depending on whether you are shooting still images, shooting movies, or shooting slow-motion/quick-motion movies.
- ISO values between 50 and 25600 are available in the following situations:
  -  Shutter Type] is set to [Electronic Shut.].
  -  Shutter Type] is set to [Auto] and [Drive Mode] is set to [Cont. Shooting].
- When shooting movies, ISO values between 100 and 102400 are available. If the ISO value is set to a value larger than 102400, the setting is automatically switched to 102400. When you finish recording the movie, the ISO value returns to the original setting.
- When shooting movies, ISO values between 100 and 102400 are available. If the ISO value is set to a value smaller than 100, the setting is automatically switched to 100. When you finish recording the movie, the ISO value returns to the original setting.
- When you select [ISO AUTO] with the shooting mode set to [P], [A], [S] or [M], the ISO sensitivity will be automatically adjusted within the set range.

## ISO AUTO Min. SS

If you select [ISO AUTO] when the shooting mode is **P** (Program Auto) or **A** (Aperture Priority), you can set the shutter speed at which the ISO sensitivity starts changing.

This function is effective for shooting moving subjects. You can minimize subject blurring while also preventing camera shake.

---

**MENU** →  1 (Camera Settings 1) → [ISO AUTO Min. SS] → desired setting.

**FASTER (Faster)/FAST (Fast):** The ISO sensitivity will start to change at shutter speeds faster than [Standard], so you can prevent camera shake and subject blurring.

**STD (Standard):** The camera automatically sets the shutter speed based on the focal length of the lens.

**SLOW (Slow)/SLOWER (Slower):** The ISO sensitivity will start to change at shutter speeds slower than [Standard], so you can shoot images with less noise.

**1/16000 – 30":** The ISO sensitivity starts to change at the shutter speed you have set.

---

### Hint

- The difference in shutter speed at which ISO sensitivity starts to change between [Faster], [Fast], [Standard], [Slow], and [Slower] is 1 EV.

### Note

- If the exposure is insufficient even when the ISO sensitivity is set to [ISO AUTO Maximum] in [ISO AUTO], in order to shoot with an appropriate exposure, the shutter speed will be slower than the speed set in [ISO AUTO Min. SS].
- In the following situations, the shutter speed may not function as set:
  - When the maximum shutter speed has changed based on the  Shutter Type] setting.
  - When using the flash to shoot bright scenes. (The maximum shutter speed is limited to the flash-syncing speed of 1/250 seconds.)
  - When using the flash to shoot dark scenes with the [Flash Mode] set to [Fill-flash] or [Wireless]. (The minimum shutter speed is limited to the speed automatically determined by the camera.)



# Using the zoom

## The zoom features available with this product

The zoom feature of the product provides a higher magnification zoom by combining various zoom features. The icon displayed on the screen changes, according to the selected zoom feature.

When a power zoom lens is mounted:

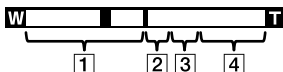

When a lens other than a power zoom lens is mounted:

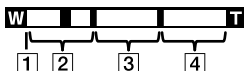

### 1 Optical zoom range

Zoom images in the zoom range of a lens. When a power zoom lens is mounted, the zoom bar of the optical zoom range is displayed. When a lens other than a power zoom lens is mounted, the zoom slider is fixed at the left end of the zoom bar while the zoom position is in the optical zoom range (displayed as  $\times 1.0$ ).

### 2 Smart Zoom range (s<sup>Q</sup>)

Zoom images without causing the original quality to deteriorate by partially cropping an image (only when the image size is [M] or [S]).





### 3 Clear Image Zoom range (c<sup>Q</sup>)

Zoom images using an image process with less deterioration. When you set [Zoom Setting] to [On: ClearImage Zoom] or [On: Digital Zoom], you can use this zoom function.

### 4 Digital Zoom range (d<sup>Q</sup>)

You can magnify images using an image process. When you set [Zoom Setting] to [On: Digital Zoom], you can use this zoom function.

## Note

- The default setting for the [Zoom Setting] is [Optical zoom only].
- The default setting for the [ Image Size] is [L]. To use the smart zoom, change [ Image Size] to [M] or [S].
- Zoom functions other than the optical zoom are not available when shooting in the following situations:
  - [ Quality] is set to [RAW] or [RAW & JPEG].
  - [ Record Setting] is set to [120p]/[100p].
  - During slow-motion/quick-motion shooting with the [ Frame Rate] set to [120fps]/[100fps]
- You cannot use the Smart Zoom function with movies.
- When a power zoom lens is mounted, you cannot use [Zoom] under MENU. If you enlarge image past the optical zoom range, the product automatically switches to another [Zoom] function than the optical zoom.
- When you use a zoom function other than the optical zoom, [Metering Mode] is fixed to [Multi].
- When using a zoom function other than the optical zoom, the following functions are not available:
  - Face Detection
  - Lock-on AF
- To use another zoom function than the optical zoom for movies, assign [Zoom] to the desired button using [Custom Key (Shoot.)] (page 170).

## Clear Image Zoom/Digital Zoom (Zoom)

When you use a zoom function other than the optical zoom, you can exceed the zoom range of the optical zoom.

---

**1** MENU →  2 (Camera Settings 2) → [Zoom Setting] → [On: ClearImage Zoom] or [On: Digital Zoom].

---

**2** When a power zoom lens is mounted, move the zoom lever or the zoom ring of the zoom lens to enlarge subjects.

- When you exceed the zoom range of the optical zoom, the camera automatically switches to another zoom than the optical zoom.

### 3 When a lens other than a power zoom lens is mounted, select MENU → 2 (Camera Settings 2) → [Zoom] → desired value.

Press the center of the control wheel to exit.

- You can also assign the [Zoom] function to the desired button by selecting MENU →  2 (Camera Settings 2) → [Custom Key (Shoot.)].

## About zoom scale

The zoom scale that is used in combination with the zoom of the lens changes according to the selected image size.

When [ Aspect Ratio] is [3:2]

Zoom Setting	 Image Size	Full-frame/APS-C	Zoom scale
Optical zoom only (including smart zoom)	L	—	—
	M	Full-frame	Approx. 1.5×
		APS-C	Approx. 1.3×
	S	Full-frame	Approx. 2×
		APS-C	Approx. 2×
	On: ClearImage Zoom	L	Full-frame
APS-C			Approx. 2×
M		Full-frame	Approx. 3×
		APS-C	Approx. 2.6×
S		Full-frame	Approx. 4×
		APS-C	Approx. 4×
On: Digital Zoom	L	Full-frame	Approx. 4×
		APS-C	Approx. 4×
	M	Full-frame	Approx. 6.1×
		APS-C	Approx. 5.2×
	S	Full-frame	Approx. 8×
		APS-C	Approx. 8×







# White Balance

Corrects the tone effect of the ambient light condition to record a neutral white subject in white. Use this function when the color tones of the image did not come out as you expected, or when you want to change the color tones on purpose for photographic expression.

---

**MENU** →  **1 (Camera Settings 1)** → **[White Balance]** → **desired setting.**

AWB   **Auto** /  **Daylight** /  **Shade** /  **Cloudy** /

 **Incandescent** /  **-1 Fluor.: Warm White** /  **0 Fluor.: Cool White** /  
 **+1 Fluor.: Day White** /  **+2 Fluor.: Daylight** /  **Flash** /

 **Underwater Auto:** When you select a light source that illuminates the subject, the product adjusts the color tones to suit to the selected light source (preset white balance). When you select [Auto], the product automatically detects the light source and adjusts the color tones.



 **C.Temp./Filter:** Adjusts the color tones depending on the light source. Achieves the effect of CC (Color Compensation) filters for photography.

 **Custom 1/Custom 2/Custom 3:** Uses the white balance setting saved in [Custom Setup].

 **Custom Setup:** Memorizes the basic white color under the light conditions for the shooting environment. Select a memorized custom white balance number.

---

## Hint

- You can display the fine adjustment screen and perform fine adjustments of the color tones as required by pressing the right side of the control wheel.
- If the color tones do not come out as you expected in the selected settings, perform [WB bracket] shooting.
-  or  is displayed only when [Priority Set in AWB] is set to [Ambience] or [White].

## Note

- [White Balance] is fixed to [Auto] in the following shooting modes:
  - [Intelligent Auto]
- If you use a mercury lamp or a sodium lamp as a light source, the accurate white balance will not be obtained because of the characteristics of the light. It is recommended to shoot images using a flash or select [Custom Setup].

## Capturing a basic white color in [Custom Setup] mode

In a scene where the ambient light consists of multiple types of light sources, it is recommended to use the custom white balance in order to accurately reproduce the whiteness. You can register 3 settings.

---

**1** MENU →  1 (Camera Settings 1) → [White Balance] → [Custom Setup].

---

**2** Hold the product so that the white area fully covers the circle located in the center of the screen, and then press the center of the control wheel.

After the shutter sound beeps, the calibrated values (Color Temperature and Color Filter) are displayed.

---

**3** Select a registration number using the left/right sides of the control wheel, and then press the center.

The monitor returns to the recording information display while retaining the memorized custom white balance setting.

- The registered custom white balance setting will remain memorized until overwritten by another setting.
-

## Note

- The message [Custom WB Error] indicates that the value is in the unexpected range, for example when the subject is too vivid. You can register the setting at this point, but it is recommended that you set the white balance again. When an error value is set, the indicator  turns orange on the recording information display. The indicator will be displayed in white when the set value is in the expected range.
- If you use a flash when capturing a shot, the custom white balance will be registered with the flash light. Shoot images with a flash when recalling a setting registered with the flash.

# Setting how to process images

## Creative Style

Allows you to set the desired image processing and finely adjust contrast, saturation and sharpness for each image style.

**1 MENU** →  **1 (Camera Settings 1)** → **[Creative Style]**.

**2 Select the desired style or [Style Box] using the top/bottom sides of the control wheel.**

-  **Standard:** For shooting various scenes with rich gradation and beautiful colors.
-  **Vivid:** The saturation and contrast are heightened for shooting striking images of colorful scenes and subjects such as flowers, spring greenery, blue sky, or ocean views.
-  **Neutral:** The saturation and sharpness are lowered for shooting images in subdued tones. This is also suitable for capturing image material to be modified with a computer.
-  **Clear:** For shooting images in clear tones with limpid colors in highlight, suitable for capturing radiant light.
-  **Deep:** For shooting images with deep and dense colors, suitable for capturing the solid presence of the subject.
-  **Light:** For shooting images with bright and simple colors, suitable for capturing a refreshingly light ambience.
-  **Portrait:** For capturing skin in a soft tone, ideally suited for shooting portraits.
-  **Landscape:** The saturation, contrast, and sharpness are heightened for shooting vivid and crisp scenery. Distant landscapes also stand out more.
-  **Sunset:** For shooting the beautiful red of the setting sun.
-  **Night Scene:** The contrast is lowered for reproducing night scenes.

**Autm** **Autumn leaves:** For shooting autumn scenes, vividly highlighting the reds and yellows of changing leaves.

**B/W** **Black & White:** For shooting images in black and white monotone.

**Sepia** **Sepia:** For shooting images in sepia monotone.

**Std.** **Registering preferred settings (Style Box):** Select the six style box (the boxes with numbers on the left side (**Std.**)) to register preferred settings. Then select the desired settings using the right button.

You can call up the same style with slightly different settings.

**3** To adjust **Contrast**, **Saturation** and **Sharpness**, select the desired item using the right/left sides, and then select the value using the top/bottom sides.

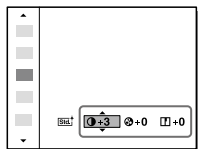

**4** When selecting [Style Box], move to the right side using the right side of the control wheel, and then select the desired style.

- You can call up the same style with slightly different settings.

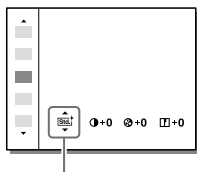

Displayed only when Style Box is selected



## ■ To set [Contrast], [Saturation] and [Sharpness]

[Contrast], [Saturation] and [Sharpness] can be adjusted for each image style preset such as [Standard] and [Landscape], and for each [Style Box] to which you can register preferred settings.

Select an item to be set by pressing the right/left sides of the control wheel, then set the value using the top/bottom sides of the control wheel.

- ① **Contrast:** The higher the value selected, the more the difference of light and shadow is accentuated, and the bigger the effect on the image.
- ② **Saturation:** The higher the value selected, the more vivid the color. When a lower value is selected, the color of the image is restrained and subdued.
- ③ **Sharpness:** Adjusts the sharpness. The higher the value selected, the more the contours are accentuated, and the lower the value selected, the more the contours are softened.



### Note

- [Creative Style] is fixed to [Standard] in the following situations:
  - [Intelligent Auto]
  - [Picture Effect] is set to other than [Off].
- When this function is set to [Black & White] or [Sepia], [Saturation] cannot be adjusted.

## Color Space

The way colors are represented using combinations of numbers or the range of color reproduction is called “color space.” You can change the color space depending on the purpose of the image.

---

**MENU** → 1 (Camera Settings 1) → [ Color Space] → **desired setting.**

**sRGB:** This is the standard color space of the digital camera. Use [sRGB] in normal shooting, such as when you intend to print out the images without any modification.

**AdobeRGB:** This color space has a wide range of color reproduction. When a large part of the subject is vivid green or red, Adobe RGB is effective. The file name of the recorded image starts with “\_.”

---

### Note

- [AdobeRGB] is for applications or printers that support color management and DCF2.0 option color space. Images may not be printed or viewed in the correct colors if you use applications or printers that do not support Adobe RGB.
- When displaying images that were recorded with [AdobeRGB] on non-Adobe RGB-compliant devices, the images will be displayed with low saturation.

# Reducing blur

Sets whether or not to use the SteadyShot function.

**MENU** →  **2 (Camera Settings 2)** → **[SteadyShot]** → **desired setting.**

**On:** Uses [SteadyShot].

**Off:** Does not use [SteadyShot]. We recommend that you set [Off] when using a tripod.

## SteadyShot Settings

You can shoot with an appropriate SteadyShot setting for the attached lens.

**1 MENU** →  **2 (Camera Settings 2)** → **[SteadyShot]** → **[On].**

**2 [SteadyShot Settings]** → **[SteadyShot Adjust.]** → **desired setting.**



**Auto:** Performs the SteadyShot function automatically according to the information obtained from the attached lens.

**Manual:** Performs the SteadyShot function according to the focal-length set using [SteadyS. Focal Len.]. (8mm – 1000mm)

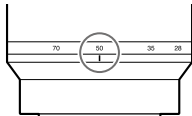
- Check the focal-length index and set the focal-length.





## Note

- The SteadyShot function may not work optimally when the power has just been turned on, right after you point the camera towards a subject, or when the shutter button has been pressed all the way down without stopping halfway.
- When using a tripod, make sure to turn off the SteadyShot function because this can cause any malfunction when shooting.
- [SteadyShot Settings] will be unavailable when MENU →  2 (Camera Settings 2) → [SteadyShot] is set to [Off].
- When the camera cannot obtain focal length information from the lens, the SteadyShot function does not work correctly. Set [SteadyShot Adjust.] to [Manual] and set [SteadyS. Focal Len.] to match the lens you are using. The current set value of the SteadyShot focal length will display to the side of .
- When using an SEL16F28 lens (sold separately) with a teleconverter, etc., set [SteadyShot Adjust.] to [Manual] and set the focal length.
- When you set [SteadyShot] to [On]/[Off], the SteadyShot settings of the camera and lens switch at the same time.
- If a lens equipped with a SteadyShot switch is attached, the settings can only be changed using that switch on the lens. You cannot switch the settings using the camera.

# Noise reduction

## Long Exposure NR





When you set the shutter speed to 1 second(s) or longer (long exposure shooting), noise reduction is turned on for the duration that the shutter is open. With the function turned on, the grainy noise typical of long exposures is reduced.

**MENU** → 1 (Camera Settings 1) →  Long Exposure NR → **desired setting.**

**On:** Activates noise reduction for the same duration that the shutter is open. When noise reduction is in progress, a message appears and you cannot take another picture. Select this to prioritize the image quality.

**Off:** Does not activate noise reduction. Select this to prioritize the timing of shooting.



### Note

-  Long Exposure NR is not available when  Shutter Type is set to [Electronic Shut.].
- Noise reduction may not be activated even if  Long Exposure NR is set to [On] in the following situations:
  - [Drive Mode] is set to [Cont. Shooting] or [Cont. Bracket].
-  Long Exposure NR cannot be set to [Off] in the following shooting modes:
  - [Intelligent Auto]
- Depending on the shooting conditions, the camera may not perform noise reduction, even if the shutter speed is 1 second(s) or longer.

## High ISO NR

When shooting with high ISO sensitivity, the product reduces noise that becomes more noticeable when the product sensitivity is high.

---

**MENU** →  1 (Camera Settings 1) → [ High ISO NR] → **desired setting.**





**Normal:** Activates high ISO noise reduction normally.

**Low:** Activates high ISO noise reduction moderately.

**Off:** Does not activate high ISO noise reduction. Select this to prioritize the timing of shooting.

---

### Note

- [ High ISO NR] is not available in the following shooting modes:
  - [Intelligent Auto]
- When [ Quality] is set to [RAW], this function is not available.
- [ High ISO NR] does not work for RAW images when the [ Quality] is [RAW & JPEG].

# Face Detection

Detects the faces of your subjects and adjusts the focus, exposure, flash settings and performs image processing automatically.

**MENU** → 1(Camera Settings 1) → [Face Detection] → desired setting.

**Off:** Does not use the [Face Detection] function.

**On (Regist. Faces):** Detects the registered face with higher priority using [Face Registration] (page 211).

**On:** Detects a face without giving higher priority to the registered face.

## Face Detection frame

- When the product detects a face, the gray face detection frame appears. When the product determines that autofocus is enabled, the face detection frame turns white. When you press the shutter button halfway down, the frame turns green.
- In case you have registered the priority order for each face using [Face Registration], the product automatically selects the first prioritized face and the face detection frame over that face turns white. The face detection frames of other registered faces turn reddish-purple.

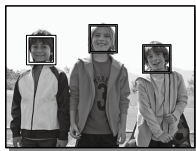

### Note

- You cannot use the Face Detection function with the following functions:
  - Other zoom functions than the optical zoom
  - [Picture Effect] is set to [Posterization].
  - When using the [Focus Magnifier] function.
  - [Record Setting] is set to [120p]/[100p].
  - [S&Q Frame Rate] is set to [120fps]/[100fps].
- Up to 8 faces of your subjects can be detected.
- The product may not detect faces at all or may accidentally detect other objects as faces in some conditions.

# Using flash (sold separately)

In dark environments, use the flash to light up the subject while shooting. Also use the flash to prevent camera-shake. For details on the flash, refer to the instruction manual for the flash.

---

## 1 Attach the flash (sold separately) to the product.

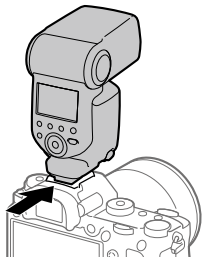

## 2 Shoot after you have turned on the flash and it is fully charged.

⚡ blinking: Charging is in progress

⚡ lit up: Charging is finished

- The available flash modes depend on the shooting mode and function.
- 

### Note

- A flash cannot be used when [📷 Shutter Type] is set to [Electronic Shut.].
- A flash can be used during continuous shooting with [📷 Shutter Type] set to [Auto]. The mechanical shutter will be used.
- The light of the flash may be blocked if the lens hood is attached and the lower part of a recorded image may be shaded. Remove the lens hood.
- When using the flash, stand 1 m or more away from the subject.
- You cannot use the flash when recording movies. (You can use an LED light when using a flash (sold separately) with an LED light.)
- Before attaching/removing an accessory such as a flash to/from the Multi Interface Shoe, turn off the product first. When attaching an accessory, make sure that the accessory is fixed securely to the product.



- Do not use the Multi Interface Shoe with a commercially available flash that applies voltage of 250 V or more or has the reverse polarity of the camera. Doing so may cause a malfunction.
- You can use a flash of the reverse polarity with the Sync Terminal. Please use a flash with a sync voltage of 400 V or less.
- When shooting with the flash and the zoom is set to W, the shadow of the lens may appear on the screen, depending on the shooting conditions. If this happens, shoot away from the subject or set the zoom to T and shoot with the flash again.
- The corners of a recorded image may be shaded, depending on the lens.
- When shooting with an external flash, light and dark stripes may appear on the image if the shutter speed is set to faster than 1/4000 seconds. If this occurs, Sony recommends shooting in the manual flash mode and setting the flash level to 1/2 or higher.
- For details on compatible accessories for the Multi Interface Shoe, visit the Sony website, or consult your Sony dealer or local authorized Sony service facility.

## Flash Mode

You can set the flash mode.

**MENU** →  1 (Camera Settings 1) → [Flash Mode] → desired setting.

 **Flash Off:** The flash does not operate.

 **Autoflash:** The flash works in dark environments or when shooting towards bright light.

 **Fill-flash:** The flash works every time you trigger the shutter.

 **Slow Sync.:** The flash works every time you trigger the shutter. Slow sync shooting allows you to shoot a clear image of both the subject and the background by slowing the shutter speed.

 **Rear Sync.:** The flash works right before the exposure is completed every time you trigger the shutter. Rear sync shooting allows you to shoot a natural image of the trail of a moving subject such as a moving car or a walking person.

 **Wireless:** Using a wireless flash creates a shading effect that gives the subject a more 3D appearance than when using an attached flash. This mode is effective when you attach a remote control-compatible external flash (sold separately) to the product, and shoot with a wireless flash (sold separately), placed away from the product.

---

#### Note

- The default setting depends on the shooting mode.
- Some [Flash Mode] settings are not available, depending on the shooting mode.

## Flash Comp.

Adjusts the amount of flash light in a range of -3.0 EV to +3.0 EV. Flash compensation changes the amount of flash light only. Exposure compensation changes the amount of flash light along with the change of the shutter speed and aperture.

---

**MENU** →  **1 (Camera Settings 1)** → **[Flash Comp.]** → **desired setting.**

- Selecting higher values (+ side) makes the flash level higher, and lower values (- side) makes the flash level lower.
- 

#### Note

- [Flash Comp.] does not work when the shooting mode is set to the following modes:
  - [Intelligent Auto]
- The higher flash effect (+ side) may not be visible due to the limited amount of flash light available, if the subject is outside the maximum range of the flash. If the subject is very close, the lower flash effect (- side) may not be visible.
- If you attach an ND filter to the lens or attach a diffuser or a color filter to the flash, the appropriate exposure may not be achieved and images may turn out dark. In this case, adjust [Flash Comp.] to the desired value.

## FEL lock

The flash level is automatically adjusted so that the subject gets the optimum exposure during normal flash shooting. You can also set the flash level in advance.

FEL: Flash Exposure Level

**1 MENU** →  **2 (Camera Settings 2)** → **[Custom Key (Shoot.)]** → **desired button**, then assign the **[FEL Lock toggle]** function to the button.

**2 Center the subject on which FEL is to be locked, and adjust the focus.**



**3 Press the button to which [FEL Lock toggle] is registered, and set the flash amount.**

- A pre-flash flashes.
- The  (FEL lock) lights up.

**4 Adjust the composition and shoot the image.**

- When you want to release the FEL lock, press the button to which the [FEL Lock toggle] is registered again.



## Flashes that support FEL lock

- HVL-F60M, HVL-F43M and HVL-F32M can be used as clip-ons, off-camera connected by a cable, and for wireless flash shooting (controller/remote).
- HVL-F20M can be used as a clip-on, off-camera connected with a cable, and for wireless flash shooting (controller).

### Hint

- By setting [FEL Lock hold], you can hold the setting while the button is pressed down. Also, by setting [FEL Lock/AEL hold] and [FEL Lock/AEL toggle], you can shoot images with the AE locked in the following situations.
  - When [Flash Mode] is set to [Flash Off] or [Autoflash].
  - When the flash cannot go off.
  - When using an external flash that is set to manual flash mode.

### Note

- The FEL lock cannot be set when a flash is not attached.
- If a flash that does not support the FEL lock is attached, an error message is displayed.
- When both AE and FEL lock are fixed,  lights up.

## Wireless flash shooting

There are two ways to use the wireless flash. One way uses a light signal and the other uses a radio signal to communicate with the flash. The flash attached to the camera must be the controller in light signal flash shooting and a Wireless Radio Commander (sold separately) is required for radio signal wireless flash shooting. For details on how to set each method, refer to the instruction manual of the flash or the Wireless Radio Commander.

---

### 1 Remove the shoe cap from the camera, and then attach the flash or the Wireless Radio Commander.

- In light signal wireless flash shooting, set the attached flash as the controller.

---

### 2 MENU → 1 (Camera Settings 1) → [Flash Mode] → [Wireless].

---

### 3 Set up an off-camera flash that is set to wireless mode, or that is attached to the Wireless Radio Receiver (sold separately).

- Press the AEL button on the camera to perform a test flashing.
- 

#### ■ Setting of the AEL button

We recommend that you set MENU →  2 (Camera Settings 2) → [Custom Key (Shoot.)] → [AEL Button] to [AEL hold] when performing wireless flash shooting.

#### Note

- The off-camera flash may emit light after receiving a light signal from a flash used as the controller of another camera. If this occurs, change the channel of your flash. For details on how to change the channel, refer to the instruction manual for the flash.
- Two flashes (a controller and an off-camera flash) are required for light signal wireless flash shooting.
- HVL-F20M can only be used as the controller.

## Using a flash with a sync terminal cord

Open the cover of ⚡ (flash sync) terminal, and connect the cord.

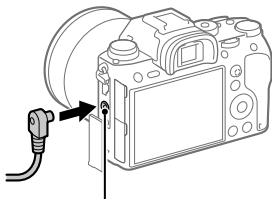

⚡ (flash sync) terminal

### Hint

- If the screen is too dark to check the composition, set [Live View Display] to [Setting Effect OFF] to make it easy to check the composition when shooting with a flash.
- Flashes that have a sync terminal with reversed polarity can be used with this product.

### Note

- Set the exposure mode to manual exposure (other than ISO AUTO is recommended for ISO sensitivity), and set the shutter speed to the slower of the following values or slower:
  - 1/200 seconds
  - The shutter speed recommended by the flash.
- Use flashes with a sync voltage of 400 V or lower.
- Turn off the flash connected to the sync cord when you connect the sync cord to the ⚡ (flash sync) terminal. Otherwise, the flash may emit light when the sync cord is connected.
- The flash power level is set to full power. [Flash Comp.] cannot be set.
- Auto white balance function is not recommended. Use the custom white balance function to achieve a more accurate white balance (page 121).
- When a flash is connected to the ⚡ (flash sync) terminal, the flash indicator will not be displayed.
- Flash cannot be used when [Shutter Type] is set to [Electronic Shut.].

## Shooting movies

You can record movies by pressing the MOVIE (Movie) button.

### 1 Press the MOVIE button to start recording.

- Since the [MOVIE Button] is set to [Always] in the default setting, movie recording can be started from any shooting mode.

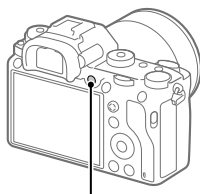

MOVIE button



### 2 Press the MOVIE button again to stop recording.

#### Hint

- You can assign the start/stop movie recording function to a preferred key. MENU → 2 (Camera Settings 2) → [Custom Key (Shoot.)] → set the function to the preferred key.
- When you want to specify the area to be focused on, set the area using [Focus Area].
- To keep the focus on a face, arrange the composition so that the focusing frame and face detection frame overlap, or set the [Focus Area] to [Wide].
- You can focus quickly while shooting movies by pressing the shutter button halfway down. (The sound of auto focus operation may be recorded in some cases.)
- To adjust the shutter speed and aperture value to the desired settings, set the shooting mode to (Movie) and select the desired exposure mode.

- The following settings for still image shooting are applied to the movie shooting:
  - White Balance
  - Creative Style
  - Metering Mode
  - Face Detection
  - D-Range Opt.
  - Lens Comp.
- You can change the settings for ISO sensitivity, exposure compensation, and focus area while shooting movies.
- While shooting movies, the recorded image can be output without the shooting information display by setting [HDMI Info. Display] to [Off].

### Note

- The sound of the lens and the product in operation may be recorded during movie recording. You can turn the sound off by selecting MENU →  2 (Camera Settings 2) → [Audio Recording] → [Off].
- When shooting, the sound of the shoulder strap hooks (triangular hook) could be recorded, depending on the situation used.
- To prevent the operating sound of the zoom ring from being recorded during movie recording when a power zoom lens is used, we recommend recording movies using the zoom lever. When you move the zoom lever, place your finger lightly on the lever and operate it without flicking.
- The temperature of the camera tends to rise when shooting movies continuously, and you may feel that the camera is hot. This is not a malfunction.  
Also, [Internal temp. high. Allow it to cool.] may appear. In such cases, turn the camera off and wait until the camera is ready to shoot again.
- When the  icon appears, the temperature of the camera is too high.
- For the continuous shooting time of a movie recording, refer to “Recordable movie times” (page 249). When movie recording is finished, you can restart recording by pressing the MOVIE button again. Recording may stop to protect the product, depending on the temperature of the product or the battery.
- When the mode dial is set to  (Movie) or **S&Q** or when shooting movies, you cannot select [Lock-on AF] for [Focus Area].
- In [Program Auto] mode when shooting movies, the aperture value and the shutter speed will be set automatically and cannot be changed. For that reason, the shutter speed may become fast in a bright environment, and the motion of the subject may not record smoothly. By changing the exposure mode and adjusting the aperture value and the shutter speed, the motion of the subject can be recorded smoothly.



- In movie shooting mode, ISO sensitivity can be selected from ISO 100 to ISO 102400. If the ISO value is set to a value smaller than ISO 100, the setting is automatically switched to ISO 100. When you finish recording the movie, the ISO value returns to the original setting.
- In movie shooting mode, the following settings cannot be set in [Picture Effect]. When a movie recording starts, [Off] will be set temporarily.
  - Rich-tone Mono.
- If you point the camera at an extremely strong light source while shooting a movie at low ISO sensitivity, the highlighted area in the image may be recorded as a black area.
- If the display mode of the monitor is set to [For viewfinder], the display mode will switch to [Display All Info.] when movie shooting starts.
- Use PlayMemories Home when importing XAVC S movies, AVCHD movies, and MP4 movies to a computer.

## ■ Movie w/ shutter

You can start or stop recording movies by pressing the shutter button, which is bigger and easier to press than the MOVIE (Movie) button.

**MENU** →  **2 (Camera Settings 2)** → **[Movie w/ shutter]** → **desired setting.**

**On:** Enables movie recording using the shutter button when the shooting mode is set to [Movie] or [S&Q Motion].

**Off:** Disables movie recording using the shutter button.

### Hint

- When [Movie w/ shutter] is set to [On], you can still start or stop recording movies using the MOVIE button.
- When [Movie w/ shutter] is set to [On], you can use the shutter button to start or stop recording movies on an external recorder using  REC Control (page 185).



### Note

- When [Movie w/ shutter] is set to [On], you cannot focus by pressing the shutter button halfway down during movie recording.

# Changing settings for movie recording



## File Format

Selects the movie file format.

**MENU** →  2 (Camera Settings 2) →  [File Format] → **desired setting.**

**XAVC S 4K:** Records 4K movies in the XAVC S format. This format supports a high bit rate.

Audio: LPCM

- One of the following kinds of memory cards is needed to record movies with  [File Format] set to [XAVC S 4K]:
  - Memory Stick PRO-HG Duo
    - Movies cannot be recorded at 100 Mbps or more.
  - SDHC/SDXC/microSDHC/microSDXC memory card (SD Speed Class 10, or UHS Speed Class U1 or faster)
    - UHS Speed Class U3 is required to record at 100 Mbps or more.
- [HDMI Info. Display] temporarily switches to [Off] when  [File Format] is set to [XAVC S 4K].
- Images will not appear on the monitor of the camera if you record movies while the camera is connected to an HDMI device with  [File Format] set to [XAVC S 4K].

**XAVC S HD:** Records HD movies in the XAVC S format. This format supports a high bit rate.

Audio: LPCM

- One of the following kinds of memory cards is needed to record movies with  [File Format] set to [XAVC S HD]:
  - Memory Stick PRO-HG Duo
    - Movies cannot be recorded at 100 Mbps or more.
  - SDHC/SDXC/microSDHC/microSDXC memory card (SD Speed Class 10, or UHS Speed Class U1 or faster)
    - UHS Speed Class U3 is required to record at 100 Mbps or more.

**AVCHD:** Records HD movies in the AVCHD format. This file format is suitable for high-definition TV.

Audio: Dolby Digital

**MP4:** Records MP4 (AVC) movies. This format is suitable for playback on smartphones or tablets, web uploads, email attachments, etc.

Audio: AAC

#### Hint

- You can save images to a computer or copy them to a disc compatible with your playback device using the PlayMemories Home software.

#### Note

- When [File Format] is set to [AVCHD], the file size of movies is limited to approx. 2 GB. If the movie file size reaches approx. 2 GB during recording, a new movie file will be created automatically.
- When [File Format] is set to [MP4], the file size of movies is limited to approx. 4 GB. If the movie file size reaches approx. 4 GB during recording, recording will stop automatically.

## Record Setting

Selects the image size, frame rate, and image quality for movie recording. The higher the bit-rate, the higher the image quality.

**MENU** →  **2 (Camera Settings 2)** → [Record Setting] → **desired setting.**

### When [File Format] is set to [XAVC S 4K]

Records high-definition movies by converting them into the MP4 file format using the MPEG-4 AVC/H.264 codec.

Frame rate	Bit-rate	
	60 Mbps	100 Mbps
30p/25p	30p 60M/25p 60M	30p 100M/25p 100M
24p	24p 60M*	24p 100M*

\* Only when [NTSC/PAL Selector] is set to NTSC

## When [File Format] is set to [XAVC S HD]

Records high-definition movies by converting them into the MP4 file format using the MPEG-4 AVC/H.264 codec.

Frame rate	Bit-rate		
	50 Mbps	60 Mbps	100 Mbps
120p/100p	—	120p 60M/ 100p 60M	120p 100M/ 100p 100M
60p/50p	60p 50M/ 50p 50M	—	—
30p/25p	30p 50M/ 25p 50M	—	—
24p	24p 50M*	—	—

\* Only when [NTSC/PAL Selector] is set to NTSC

## When [File Format] is set to [AVCHD]

60i/50i: Movies are recorded at approximately 60 fields/sec (for 1080 60i-compatible devices) or 50 fields/sec (for 1080 50i-compatible devices) in interlaced mode with Dolby Digital audio and in the AVCHD format.

24p/25p: Movies are recorded at approximately 24 frames/sec (for 1080 60i-compatible devices) or 25 frames/sec (for 1080 50i-compatible devices) in progressive mode with Dolby Digital audio and in the AVCHD format.

60p/50p: Movies are recorded at approximately 60 frames/sec (for 1080 60i-compatible devices) or 50 frames/sec (for 1080 50i-compatible devices) in progressive mode with Dolby Digital audio and in the AVCHD format.

Frame rate	Bit-rate		
	17 Mbps	24 Mbps	28 Mbps
60i/50i	60i 17M (FH)/ 50i 17M (FH)	60i 24M (FX)/ 50i 24M (FX)	—
60p/50p	—	—	60p 28M (PS)/ 50p 28M (PS)
24p/25p	24p 17M (FH)/ 25p 17M (FH)	24p 24M (FX)/ 25p 24M (FX)	—

## When [File Format] is set to [MP4]

Movies are recorded in the MPEG-4 format, at approximately 60 frames/sec (for 1080 60i-compatible devices), approximately 50 frames/sec (for 1080 50i-compatible devices), approximately 30 frames/sec (for 1080 60i-compatible devices), or approximately 25 frames/sec (for 1080 50i-compatible devices), in progressive mode with AAC audio and in the MP4 format.

Frame rate	Bit-rate		
	6 Mbps	16 Mbps	28 Mbps
60p/50p	—	—	1920×1080 60p 28M/50p 28M
30p/25p	1280×720 30p 6M/25p 6M	1920×1080 30p 16M/25p 16M	—

### Note

- Movies recorded with [60p 28M (PS)]/[50p 28M (PS)]/[60i 24M (FX)]/[50i 24M (FX)]/[24p 24M (FX)]/[25p 24M (FX)] as the [Record Setting] are converted by PlayMemories Home in order to create an AVCHD recording disc. You cannot create a disc in the original image quality. The conversion can take a long time. If you want to keep the original image quality, store your movies on a Blu-ray Disc.
- To play back 60p/50p/24p/25p movies on a TV, the TV must be compatible with the 60p/50p/24p/25p format. If the TV is not compatible with the 60p/50p/24p/25p format, 60p/50p/24p/25p movies will be output as 60i/50i movies.
- [120p]/[100p] cannot be selected for the following settings.
  - [Intelligent Auto]
- In full-frame shooting, the angle of view will be narrower under the following conditions:
  - When [File Format] is set to [XAVC S 4K] and [Record Setting] is set to [30p]

## ■ Angle of view during movie recording

The angle of view during movie recording depends on the settings for [File Format], [Record Setting], etc.

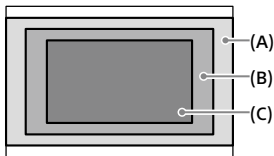

### (A) Angle of view equivalent to full-frame

- When [File Format] is set to [XAVC S 4K] and [Record Setting] is set to [24p 60M]/[24p 100M]/[25p 60M]/[25p 100M]
- When [File Format] is set to [XAVC S HD], [AVCHD] or [MP4]
- When the mode dial is set to **S&Q**

### (B) Angle of view equivalent to approx. 1.2 times the focal length indicated on the lens

- When [File Format] is set to [XAVC S 4K] and [Record Setting] is set to [30p 60M] or [30p 100M]

### (C) Angle of view equivalent to approx. 1.5 times the focal length indicated on the lens

- When [APS-C/Super 35mm] is set to [On]
- When [APS-C/Super 35mm] is set to [Auto] and an APS-C size dedicated lens is attached

## S&Q S&Q Settings

You can record a moment that cannot be captured by the naked eye (slow-motion recording), or record a long-term phenomenon into a compressed movie (quick-motion recording). For example, you can record an intense sports scene, the moment when a bird starts to fly, a blooming flower, and a changing view of clouds or a starry sky. Sound will not be recorded.

---

### 1 Set the mode dial to S&Q (S&Q Motion).

---

### 2 Select MENU → 2 (Camera Settings 2) → [S&Q Exposure Mode] → and select the desired setting of slow-motion/quick-motion (S&Q Program Auto, S&Q Aperture Priority, S&Q Shutter Priority, or S&Q Manual Exposure).

---

### 3 Select MENU → 2 (Camera Settings 2) → [S&Q S&Q Settings] and select the desired settings for [S&Q Record Setting] and [S&Q Frame Rate].

**S&Q Record Setting:** Selects the frame rate of the movie.

**S&Q Frame Rate:** Selects the shooting frame rate.

---

### 4 Press the MOVIE (movie) button to start recording.

- Press the MOVIE button again to stop recording.
-

## ■ Playback speed

The playback speed will vary as below depending on the assigned [S&Q Record Setting] and [S&Q Frame Rate].

### When [NTSC/PAL Selector] is set to NTSC

[S&Q Frame Rate]	[S&Q Record Setting]		
	24p	30p	60p
120fps	5 times slower	4 times slower	—
60fps	2.5 times slower	2 times slower	Normal playback speed
30fps	1.25 times slower	Normal playback speed	2 times quick
15fps	1.6 times quick	2 times quick	4 times quick
8fps	3 times quick	3.75 times quick	7.5 times quick
4fps	6 times quick	7.5 times quick	15 times quick
2fps	12 times quick	15 times quick	30 times quick
1fps	24 times quick	30 times quick	60 times quick

### When [NTSC/PAL Selector] is set to PAL

[S&Q Frame Rate]	[S&Q Record Setting]	
	25p	50p
100fps	4 times slower	—
50fps	2 times slower	Normal playback speed
25fps	Normal playback speed	2 times quick
12fps	2.08 times quick	4.16 times quick
6fps	4.16 times quick	8.3 times quick
3fps	8.3 times quick	16.6 times quick
2fps	12.5 times quick	25 times quick
1fps	25 times quick	50 times quick

- When [S&Q Frame Rate] is set to [120fps]/[100fps], you cannot set [S&Q Record Setting] to [60p]/[50p].



**Note**

- In slow-motion recording, the shutter speed becomes faster and you may not be able to obtain the proper exposure. If this happens, decrease the aperture value or adjust the ISO sensitivity to a higher value.
- For an estimation of recordable time, refer to “Recordable movie times” (page 249).
- The bit-rate of a recorded movie varies depending on the settings for [S&Q Frame Rate] and [S&Q Record Setting].
- The movie will be recorded in XAVC S HD format.
- During slow-motion/quick-motion recording, the following functions are not available.
  - [Dual Video REC]
  - [TC Run] under [TC/UB Settings]
  - [TC Output] under [HDMI Settings]
  - [4K Output Sel.]

## Audio Recording

Sets whether to record sounds when shooting movies. Select [Off] to avoid recording the sounds of the lens and the camera operating.

---

**MENU** →  **2 (Camera Settings 2)** → **[Audio Recording]** → **desired setting.**

**On:** Records sound (stereo).

**Off:** Does not record sound.

---

## Audio Rec Level

You can adjust the audio recording level while checking the level meter.

---

**1 MENU** →  **2 (Camera Settings 2)** → **[Audio Rec Level]**.

---

**2 Select the desired level using the right/left sides of the control wheel.**

**+**: Turns up the audio recording level.

**-**: Turns down the audio recording level.

**Reset:** Resets the audio recording level to the default setting.

---

### Hint

- When you record audio movies with loud volumes, set [Audio Rec Level] to a lower sound level. Doing so enables you to record more realistic audio. When you record audio movies with lower volumes, set [Audio Rec Level] to a greater sound level to make the sound easier to hear.

### Note

- Regardless of the [Audio Rec Level] settings, the limiter always operates.
- [Audio Rec Level] is available only when the shooting mode is set to movie mode.
- [Audio Rec Level] is unavailable during slow-motion/quick-motion shooting.
- The [Audio Rec Level] settings are applied for both the internal microphone and the  (microphone) terminal input.

## Marker Settings

### Marker Display

Sets whether or not to display markers set using [Marker Settings] on the monitor or the viewfinder while shooting movies.

**MENU** →  **2 (Camera Settings 2)** → [Marker Display] → **desired setting.**

**On:** Markers are displayed. The markers are not recorded.

**Off:** No marker is displayed.

#### Note

- The markers are displayed when the mode dial is set to  (Movie) or S&Q, or when shooting movies.
- You cannot display markers when using [Focus Magnifier].
- The markers are displayed on the monitor or viewfinder. (You cannot output the markers.)

### Marker Settings

Sets the markers to be displayed while shooting movies.

**MENU** →  **2 (Camera Settings 2)** → [Marker Settings] → **desired setting.**

**Center:** Sets whether or not to display the center marker in the center of the shooting screen.  
[Off] / [On]

**Aspect:** Sets the aspect marker display.  
[Off] / [4:3] / [13:9] / [14:9] / [15:9] / [1.66:1] / [1.85:1] / [2.35:1]

**Safety Zone:** Sets the safety zone display. This becomes the standard range that can be received by a general household TV.  
[Off] / [80%] / [90%]

**Guideframe:** Sets whether or not to display the guide frame. You can verify whether the subject is level or perpendicular to the ground.  
[Off] / [On]

#### Hint

- You can display several markers at the same time.
- Place the subject on the cross point of the [Guideframe] to make a balanced composition.

## 4K Output Sel.

You can set how to record movies and perform HDMI output when your camera is connected to 4K-compatible external recording/playback devices, etc.

### 1 Turn the mode dial to (Movie).

### 2 Connect the camera to the desired device via an HDMI cable.

### 3 MENU → (Setup) → 4K Output Sel.] → desired setting.

**Memory Card + HDMI:** Simultaneously outputs to the external recording/playback device and records on the camera's memory card.

**HDMI Only (30p):** Outputs a 4K movie in 30p to the external recording/playback device without recording on the camera's memory card.

**HDMI Only (24p):** Outputs a 4K movie in 24p to the external recording/playback device without recording on the camera's memory card.

**HDMI Only (25p)\*:** Outputs a 4K movie in 25p to the external recording/playback device without recording on the camera's memory card.

\* Only when [NTSC/PAL Selector] is set to PAL.

#### Note

- This item can be set only when the camera is in movie mode and connected to a 4K-compatible device.
- When [HDMI Only (30p)], [HDMI Only (24p)] or [HDMI Only (25p)] is set, [HDMI Info. Display] will temporarily be set to [Off].
- A 4K movie is not output to the connected 4K-compatible device during slow-motion/quick-motion shooting.
- When [HDMI Only (30p)], [HDMI Only (24p)] or [HDMI Only (25p)] is set, the counter does not move forward (the actual recording time is not counted) while the movie is being recorded on an external recording/playback device.
- When  File Format] is set to [XAVC S 4K] and [Dual Video REC] is set to [On], the following functions are not available.
  - [Face Detection]
  - [Center Lock-on AF]

## Viewing images

### Playing back still images

Plays back the recorded images.

---

**1** Press the  (Playback) button to switch to the playback mode.

---

**2** Select the image with the control wheel.

---

#### Hint

- The product creates an image database file on a memory card to record and play back images. An image that is not registered in the image database file may not be played back correctly. To play back images shot using other devices, register those images to the image database file using MENU →  (Setup) → [Recover Image DB].
- If you play back the images right after continuous shooting, the monitor may display an icon indicating that data is being written/the number of images left to write (page 223). During writing, some functions are not available.
- You can also enlarge an image by double-tapping the monitor. In addition, you can drag and move the magnified position on the monitor. Set [Touch Operation] to [On] beforehand.

## Enlarging an image being played back (Playback zoom)

Enlarges the image being played back. Use this function to check the focus of the image, etc.



### 1 Display the image you want to enlarge, and then press the button.

- Turn the control wheel to adjust the zoom scale. By rotating the front/rear dial, you can switch to the previous or next image while keeping the same zoom scale.
- The view will zoom in on the part of the image where the camera focused during shooting. If the focus location information cannot be obtained, the camera will zoom in on the center of the image.

### 2 Select the portion you want to enlarge by pressing the top/bottom/right/left sides of the control wheel.

### 3 Press the MENU button or the center of the control wheel to exit the playback zoom.

#### Hint

- You can also enlarge an image being played back using MENU.
- You can change the initial magnification and initial position of enlarged images by selecting MENU →  (Playback) → [ Enlarge Init. Mag.] or [ Enlarge Initial Pos.].
- You can also enlarge an image by double-tapping the monitor. In addition, you can drag and move the magnified position on the monitor. Set [Touch Operation] to [On] beforehand.

#### Note

- You cannot enlarge movies.

## Rotating recorded images automatically (Display Rotation)

Selects the orientation when playing back recorded images.

---

**MENU** →  (**Playback**) → [**Display Rotation**] → **desired setting**.

**Auto:** When you rotate the camera, the displayed image rotates automatically by detecting the orientation of the camera.

**Manual:** Images shot vertically are displayed vertically. If you have set the image orientation using the [Rotate] function, the image will be displayed accordingly.

**Off:** Images are always displayed horizontally.

---

## Playing back movies

Plays back the recorded movies.

---

**1** Press the  (**playback**) button to switch to playback mode.













---

**2** Select the movie to be played back using the control wheel and press the center of the control wheel to start playback.

---

## Available operations during movie playback

You can perform slow playback and sound volume adjustment, etc. by pressing the down side of the control wheel.

Operation panel	Available operation
	Playback
	Pause
	Fast-forward
	Fast-rewind
	Forward slow playback
	Reverse slow playback
	Next movie file
	Previous movie file
	Displays the next frame
	Displays the previous frame
	Photo Capture
	Sound volume adjustment
	Closes the operation panel

### Hint

- “Forward slow playback,” “Reverse slow playback,” “Displays the next frame” and “Displays the previous frame” are available during pause.
- Movie files recorded using other products may not be able to be playable on this camera.



## Photo Capture

Captures a chosen scene in a movie to save as a still image. First shoot a movie, then pause the movie during playback to capture decisive moments that tend to be missed when shooting still images, and save them as still images.

---

**1** Display the movie that you want to capture as a still image.

---

**2** MENU →  (Playback) → [Photo Capture].

---

**3** Play back the movie and pause it.

---

**4** Find the desired scene using forward slow playback, reverse slow playback, displays the next frame, and displays the previous frame, and then stop the movie.

---

**5** Press  (Photo Capture) to capture the chosen scene.  
The scene is saved as a still image.

---

## Playing back images on the image index screen (Image Index)

You can display multiple images at the same time in playback mode.

---

**1** Press the  (Image Index) button while the image is being played back.

---

**2** Select the image by pressing the top/bottom/right/left sides of the control wheel or turning the control wheel.

---

## ■ To change the number of images to be displayed

MENU →  (Playback) → [Image Index] → desired setting.

9 Images/25 Images

## ■ To return to single-image playback

Select the desired image and press the center of the control wheel.

## ■ To display a desired image quickly

Select the bar on the left of the image index screen using the control wheel, then press the top/bottom sides of the control wheel. While the bar is being selected, you can display the calendar screen or folder selection screen by pressing the center. In addition, you can switch View Mode by selecting an icon.

## Switching between still images and movies (View Mode)

Sets the View Mode (image display method).

---

MENU →  (Playback) → [View Mode] → desired setting.

 **Date View:** Displays the images by date.

 **Folder View (Still):** Displays only still images.

 **MP4 Folder View (MP4):** Displays only MP4-format movies.

 **AVCHD AVCHD View:** Displays only AVCHD-format movies.

 **XAVC S HD View:** Displays only XAVC S HD-format movies.

 **XAVC S 4K View:** Displays only XAVC S 4K-format movies.

---

## Selecting which memory card to play back (Select PB Media)

Selects the memory card slot to be played back.

---

**MENU** →  (**Playback**) → [**Select PB Media**] → **desired slot**.

**Slot 1:** Selects the slot 1.

**Slot 2:** Selects the slot 2.

---

### Note

- No image is played back when no memory card is inserted in the selected slot. Select a slot into which a memory card has been inserted.
- When you select [Date View] in [View Mode], the camera only plays back images from a memory card selected using [Select PB Media].

## Copying images from one memory card to another (Copy)

You can copy images from a memory card in a slot that is selected using [Select PB Media] to a memory card in another slot.

---

**MENU** →  (**Playback**) → [**Copy**].

All of the contents with a date or in a folder currently being played back will be copied to a memory card in another slot.

---

### Hint

- You can select the type of images to be displayed by selecting MENU →  (Playback) → [View Mode].

### Note

- It may take a long time when many images are to be copied. Use a sufficiently charged battery pack.
- XAVC S movies can only be copied to a memory card that supports XAVC S movies. A message will be displayed on the monitor of the camera when images cannot be copied.

## Playing back images using slideshow (Slide Show)

Automatically plays back images continuously.

---

### 1 MENU → (Playback) → [Slide Show] → desired setting.

**Repeat:** Select [On], in which images are played back in a continuous loop, or [Off], in which the product exits the slideshow when all the images are played back once.

**Interval:** Select the display interval for images from among [1 Sec], [3 Sec], [5 Sec], [10 Sec] or [30 Sec].

---

### 2 Select [Enter].

---

### To quit the slideshow in the middle of playback

Press the MENU button to quit the slideshow. You cannot pause the slideshow.

#### Hint

- During playback, you can display the next/previous image by pressing the right/left side of the control wheel.
- You can activate a slideshow only when [View Mode] is set to [Date View] or [Folder View (Still)].

# Protecting images (Protect)

Protects recorded images against accidental erasure. The  mark is displayed on protected images.

---

**MENU** →  (Playback) → [Protect] → desired setting.

**Multiple Img.:** Applies or cancels the protection of the selected multiple images.

**All in this Folder:** Protects all images in the selected folder.

**All with this date:** Protects all images in the selected date range.

**Cancel All in this Folder:** Cancels the protection of all images in the selected folder.



**Cancel All with this date:** Cancels the protection of all images in the selected date range.

---

## Note

- The menu items that can be selected differ depending on the [View Mode] setting.

## Multiple Img.

- ① **Select the image to be protected, then press the center of the control wheel. The  mark is displayed in the check box. To cancel the selection, press the center again to remove the  mark.**
- ② **To protect other images, repeat step ①.**
- ③ **MENU** → [OK].

# Deleting images

## Deleting a displayed image

You can delete an image displayed. Once you have deleted an image, you cannot restore it. Confirm the image to be deleted beforehand.

---

**1 Display the image you want to delete.**

---

**2 Press the  (Delete) button.**

---

**3 Select [Delete] using the control wheel.**

---

### Note

- The protected images cannot be deleted.

## Deleting multiple selected images (Delete)

You can delete multiple selected images. Once you have deleted an image, you cannot restore it. Confirm the image to be deleted beforehand.

---

**MENU** →  (Playback) → [Delete] → **desired setting.**

**Multiple Img.:** Deletes the selected images.

**All in this Folder:** Deletes all images in the selected folder.

**All with this date:** Deletes all images in the selected date range.

---

### Hint

- Perform [Format] to delete all images, including protected images.
- To display the desired folder or date, select the desired folder or date during playback by performing the following procedure:  
 (Image Index) button → select the bar on the left using the control wheel  
→ select the desired folder or date using the top/bottom sides of the control wheel.

#### Note

- The protected images cannot be deleted.
- The menu items that can be selected differ depending on the [View Mode] setting.

## Multiple Img.

- ① Select the images to be deleted, then press the center of the control wheel. The ✓ mark is displayed in the check box. To cancel the selection, press the center again to remove the ✓ mark.
- ② To delete other images, repeat step ①.
- ③ MENU → [OK].

# Viewing images on a TV

## Viewing images on a TV using an HDMI cable

To view images stored on this product using a TV, an HDMI cable (sold separately) and an HD TV equipped with an HDMI jack are required.

---

**1 Turn off both this product and the TV.**

---

**2 Connect the HDMI micro terminal of this product to the HDMI jack of the TV using an HDMI cable (sold separately).**

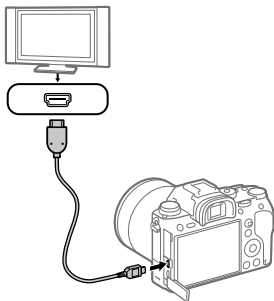

**3 Turn on the TV and switch the input.**

---

**4 Turn on this product.**

Images shot with the product appear on the TV screen.

---



**5 Select an image using the right/left sides of the control wheel.**

- The monitor of this camera is not lit up on the playback screen.
  - If the playback screen is not displayed, press the  (Playback) button.
-



## ■ “BRAVIA” Sync

By connecting this product to a TV that supports “BRAVIA” Sync using an HDMI cable (sold separately), you can operate this product’s playback functions with the TV remote control.

- ① **After performing the steps above to connect this camera to a TV, select MENU →  (Setup) → [HDMI Settings] → [CTRL FOR HDMI] → [On].**
- ② **Press the SYNC MENU button on the TV remote control, and select the desired mode.**
  - If you connect this camera to a TV using an HDMI cable, available menu items are limited.
  - Only TVs that support “BRAVIA” Sync can provide SYNC MENU operations. For details, refer to the operating instructions supplied with the TV.
  - If the product performs unwanted operations in response to the TV remote control when the product is connected to another manufacturer’s TV using an HDMI connection, select MENU →  (Setup) → [HDMI Settings] → [CTRL FOR HDMI] → [Off].

### Hint

- This product is compatible with the PhotoTV HD standard. If you connect Sony PhotoTV HD-compatible devices using an HDMI cable (sold separately), the TV is set to the image quality suitable for viewing still images, and a whole new world of photos can be enjoyed in breathtaking high quality.
- You can connect this product to Sony PhotoTV HD-compatible devices with a USB terminal using the supplied micro USB cable.
- The PhotoTV HD allows for a highly-detailed, photo-like expression of subtle textures and colors.
- For details, refer to the operating instructions supplied with the compatible TV.

## Note

- Do not connect this product and another device using the output terminals of both. Doing so may cause a malfunction.
- Some devices may not work properly when connected to this product. For example, they may not output video or audio.
- Use an HDMI cable with the HDMI logo or a genuine Sony cable.
- Use an HDMI cable that is compatible with the HDMI micro terminal of the product and the HDMI jack of the TV.
- When [TC Output] is set to [On], the image may not be output properly to the TV or recording device. In such cases, set [TC Output] to [Off] (page 184).
- If images do not appear on the TV screen properly, select MENU →  (Setup) → [HDMI Settings] → [HDMI Resolution] → [2160p/1080p], [1080p] or [1080i] according to the TV to be connected.
- During HDMI output, when you switch the movie from 4K to HD image quality or vice-versa, or change the movie to a different frame rate, the screen may become dark. This is not a malfunction.

## Registering frequently used functions

### 1/2 Memory

Allows you to register up to 3 often-used modes or product settings to the product and up to 4 (M1 through M4) to the memory card. You can recall the settings using just the mode dial.

---

**1 Set the product to the setting you want to register.**

---

**2 MENU** → 1 (Camera Settings 1) → [1/2 Memory] → desired number.

---

**3 Press the center of the control wheel to confirm.**

---

### Items that can be registered

- You can register various functions for shooting. The items that can actually be registered are displayed on the menu of the camera.
- Aperture (F number)
- Shutter speed

### To change registered settings

Change the setting to the desired one and re-register the setting to the same mode number.

#### Note

- M1 through M4 can be selected only when a memory card is inserted into the product.
- When registering the settings on a memory card, only a memory card that has been selected using [Select Rec. Media] can be used.
- Program Shift cannot be registered (page 98).
- For some functions, the position of the dial and the setting actually used for shooting may not match. If this happens, shoot images by referring to the information displayed on the monitor.

## Registering shooting settings to a custom key (Reg Cust Shoot Set)

You can register shooting settings (such as exposure, focus setting, drive mode, etc.) to a custom key in advance and temporarily recall them while holding down the key. Simply press the custom key to switch the settings quickly and release the key to go back to the original settings. This function is useful when recording active scenes such as sports.

---

- 1 MENU →  1 (Camera Settings 1) → [Reg Cust Shoot Set] → Select a registration number from [Recall Custom hold 1] to [Recall Custom hold 3].**

The setting screen for the selected number will be displayed.

---

- 2 Using the top/bottom/left/right side of the control wheel, select the check boxes for the functions that you want to recall with one of the registration numbers and press the center to check each box.**

A  mark will be displayed in the boxes for the functions.

- To cancel a selection, press the center again.
- 

- 3 Select the function that you want to adjust using the top/bottom/left/right side of the control wheel, and press the center to adjust the function to the desired setting.**

- Select [Import Current Setting] to register the current settings of the camera to the registration number that you chose.
- 

- 4 Select [Register].**
-

## Items that can be registered

- You can register various functions for shooting. The items that can actually be registered are displayed on the menu of the camera.
- Exposure
- Focus setting
- Drive mode (other than self-timer)

## To recall registered settings

- ① **MENU** →  **2 (Camera Settings 2)** → **[Custom Key (Shoot.)]**  
→ **Select the desired key and then select one of the registration numbers from [Recall Custom hold 1] to [Recall Custom hold 3].**
- ② **On the shooting screen, press the shutter button while holding down the key to which you assigned one of the registration numbers.**

The registered settings are activated while you are holding down the custom key.

### Hint

- You can change the settings for [Reg Cust Shoot Set] after assigning one of the registration numbers to the custom key using [Custom Key (Shoot.)].

### Note

- The registration numbers [Recall Custom hold 1] through [Recall Custom hold 3] are available only when the shooting mode is set to P/A/S/M.
- Depending on the attached lens and the status of the camera when the registered setting recall is executed, the registered settings may not take effect.

# Assigning selected functions to the button

## Custom Key (Shoot.)/Custom Key (PB)

You can assign a desired function to a desired key.

Some functions are available only when they are assigned to a custom key. For example, if you assign [Eye AF] to [Center Button] for [Custom Key (Shoot.)], you can easily recall [Eye AF] simply by pressing the center of the control wheel while shooting.

**1 MENU** →  **2 (Camera Settings 2)** → [Custom Key (Shoot.)] or [Custom Key (PB)].

**2 Select the key to which you want to assign the function on the selection screen, and then press the center of the control wheel.**

- The keys that can be assigned functions are different for [Custom Key (Shoot.)] and [Custom Key (PB)].
- You can assign the desired functions to the following keys.

- 1 AF-ON Button
- 2 Custom Button 3
- 3 Custom Button 2
- 4 Custom Button 1
- 5 AEL Button
- 6 Center Button
- 7 Control Wheel /  
Down Button / Left Button /  
Right Button
- 8 Custom Button 4
- 9 Multi-Slc Center Btn
- 10 Fn/ Button

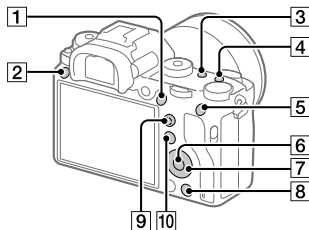

- You can also assign a shooting function to the focus hold button on the lens. However, some lenses do not have a focus hold button.

**3 Select the function to be assigned.**

- The functions that can be assigned differ depending on the keys.

## Function Menu Set.

You can assign the functions to be called up when you press the Fn (Function) button.

---

**MENU →  2 (Camera Settings 2) → [Function Menu Set.] → set a function to the desired location.**

- The functions that can be assigned are displayed on the setup item selection screen.
-

# Customizing the MENU (My Menu)

## Add Item

You can register the desired menu items to ★ (My Menu) under MENU.

- 1 MENU → ★ (My Menu) → [Add Item].**
- 2 Select an item that you want to add to ★ (My Menu) using the top/bottom/left/right sides of the control wheel.**
- 3 Select a destination using the top/bottom/left/right sides of the control wheel.**

### Hint

- You can add up to 30 items to ★ (My Menu).

### Note

- You cannot add the following items to ★ (My Menu).
  - Any item under MENU →  (Playback)
  - [View on TV]

## Sort Item

You can rearrange menu items added to ★ (My Menu) under MENU.

- 1 MENU → ★ (My Menu) → [Sort Item].**
- 2 Select an item that you want to move using the top/bottom/left/right sides of the control wheel.**
- 3 Select a destination using the top/bottom/left/right sides of the control wheel.**



## Delete Item

You can delete menu items added to ★ (My Menu) of MENU.

---

**1** MENU → ★ (My Menu) → [Delete Item].

---

**2** Select an item that you want to delete using the top/bottom/left/right sides of the control wheel, and then press the center to delete the selected item.

---

### Hint

- To delete all the items on a page, select MENU → ★ (My Menu) → [Delete Page].
- You can delete all the items added to ★ (My Menu) by selecting MENU → ★ (My Menu) → [Delete All].

# Checking images before/after recording

## Auto Review

You can check the recorded image on the screen right after the shooting. You can also set the display time for Auto Review.

---

**MENU** →  **2 (Camera Settings 2)** → **[Auto Review]** → **desired setting.**

**10 Sec/5 Sec/2 Sec:** Displays the recorded image on the screen right after shooting for the selected duration of time. If you perform a magnifying operation during Auto Review, you can check that image using the magnified scale.

**Off:** Does not display the Auto Review.

---

### Note

- When you use a function that performs image processing, the image before processing may be displayed temporarily, followed by the image after processing.
- The DISP (Display Setting) settings are applied for the Auto Review display (page 35).

## Aperture Preview

While you press and hold the key to which you assigned the [Aperture Preview] function, the aperture is stepped down to the set aperture value and you can check the blurriness prior to shooting.

---

**1 MENU** →  **2 (Camera Settings 2)** → **[Custom Key (Shoot.)]** → **set the [Aperture Preview] function to the desired key.**

---

**2 Confirm the image by pressing the key to which [Aperture Preview] was assigned.**

---

### Hint

- Although you can change the aperture value during the preview, the subject may be defocused if you select a brighter aperture. We recommend that you adjust the focus again.

## Shot. Result Preview

While pressing down the key to which [Shot. Result Preview] is assigned, you can check the image preview with the DRO, shutter speed, aperture and ISO sensitivity settings applied. Check the shooting result preview before shooting.

---

**1 MENU →  2 (Camera Settings 2) → [Custom Key (Shoot.)] → set the [Shot. Result Preview] function to the desired key.**

---

**2 Confirm the image by pressing the key to which [Shot. Result Preview] was assigned.**

---

### Hint

- The DRO settings, shutter speed, aperture and ISO sensitivity settings you have set are reflected on the image for [Shot. Result Preview], but some effects cannot be previewed depending on the shooting settings. Even in that case, the settings you have selected will be applied to the images you shoot.

# Monitor/viewfinder settings

## FINDER/MONITOR

Sets the method for switching the display between Electronic Viewfinder and the screen.

---

**MENU** →  2 (Camera Settings 2) → [FINDER/MONITOR] → **desired setting.**

**Auto:** When you look into the Electronic Viewfinder, the eye sensor reacts and the display is switched to the Electronic Viewfinder automatically.

**Viewfinder (Manual):** The screen is turned off and the image is displayed only in the Electronic Viewfinder.

**Monitor (Manual):** The Electronic Viewfinder is turned off and the image is always displayed on the screen.

---

### Hint

- You can assign the [FINDER/MONITOR] function to your preferred key.  
MENU →  2 (Camera Settings 2) → [Custom Key (Shoot.)] → set [Finder/Monitor Sel.] to the preferred key.
- To turn off automatic switching of the display using the eye sensor, set [FINDER/MONITOR] to [Viewfinder (Manual)] or [Monitor (Manual)].



### Note

- When the monitor is pulled out, the eye sensor of the camera will not detect you are approaching even if [FINDER/MONITOR] is set to [Auto]. The image will continue to be displayed on the monitor.

## Finder Frame Rate

Display the subject's movements more smoothly by adjusting the frame rate of the viewfinder during still image shooting. This function is convenient when shooting a fast-moving subject.

---

**MENU** →  **(Camera Settings 2)** → [ **Finder Frame Rate**] → **desired setting.**



- This function can be assigned to button of your choice using [Custom Key (Shoot.)].

**High:** Displays the movements of the subject more smoothly on the viewfinder.

**Standard:** Displays the subject at a normal frame rate on the viewfinder.

---

### Note

- When [ Finder Frame Rate] is set to [High], the resolution of the viewfinder is lowered.
- [ Finder Frame Rate] is locked to [Standard] in the following situations:
  - During playback
  - During HDMI connection
  - During continuous shooting with [ Shutter Type] set to [Auto] or [Electronic Shut.].

# Memory card settings

## Format

When you use a memory card with this camera for the first time, we recommend that you format the card using the camera for stable performance of the memory card. Note that formatting permanently erases all data on the memory card, and is unrecoverable. Save valuable data on a computer, etc.

---

**MENU** →  (**Setup**) → **[Format]** → **desired memory card slot.**

---

### Note

- Formatting permanently erases all data including protected images and registered settings (from M1 to M4) (page 167).
- The access lamp lights up during formatting. Do not remove the memory card while the access lamp is lit up.
- Format the memory card on this camera. If you format the memory card on the computer, the memory card may not be usable depending on the format type.
- It may take a few minutes to complete formatting, depending on the memory card.
- You cannot format the memory card if the remaining battery charge is less than 1%.

## File Number

Selects how to assign file numbers to recorded still images and MP4 movies.

---

**MENU** →  (Setup) → [File Number] → desired setting.

**Series:** The product will assign numbers to files sequentially up to “9999” without resetting.

**Reset:** The product resets numbers when a file is recorded in a new folder and assigns numbers to files starting with “0001”.

(When the recording folder contains a file, a number one higher than the largest number is assigned.)

---

### Hint

- The setting for [File Number] will be applied to both slot 1 and slot 2.
- Even if you change the setting of the recording destination, the file numbers will be sequential across the two memory cards in each slot by setting [File Number] to [Series].

## Set File Name

You can specify the first three characters of the file name for images you shoot.

---

**1 MENU** →  (Setup) → [Set File Name].

**2 Select the entry field for the file name to display a keyboard on the screen, and then enter three characters of your choice.**

- The setting for [Set File Name] will be applied to both slot 1 and slot 2.
- 

### Note

- Only capital letters, numbers, and underscores can be entered. However, an underscore cannot be used as the first character.
- The three characters of the file name you specify using [Set File Name] will only be applied to images you shoot after changing the setting.

## Recording Mode

You can select the method for recording an image, such as recording the same image simultaneously to two memory cards or recording different types of images to two memory cards. (If you want to record a movie to a memory card in different formats, use [Dual Video REC].)

---

**MENU** →  (**Setup**) → [**Recording Mode**] → **desired setting**.

**Standard:** Records an image to a memory card in the memory card slot that you select in [Select Rec. Media].

**Simult. (📷/🎥):** Records a still image to both memory cards and records a movie to a memory card in the memory card slot that you select in [Select Rec. Media].

**Simult. (📷):** Records a still image to a memory card in the memory card slot that you select in [Select Rec. Media], and records a movie to both memory cards.

**Simult. (📷/🎥):** Records a still image and a movie to both memory cards.

**Sort (JPEG/RAW):** Records an image in JPEG format to a memory card in the memory card slot that you select in [Select Rec. Media], and records an image in RAW format to the other memory card.

**Sort (📷/🎥):** Records a still image to a memory card in the memory card slot that you select in [Select Rec. Media], and records a movie to the other memory card.

---

### Note

- When [Recording Mode] is set to [Simult. (📷)] or [Simult. (📷/🎥)], [Dual Video REC] is temporarily set to [Off].
- When [Recording Mode] is set to [Sort (JPEG/RAW)], [📷 Quality] is temporarily set to [RAW & JPEG].



## Select REC Folder

If [Folder Name] is set to [Standard Form] and there are 2 folders or more, you can select the folder on the memory card to which images are to be recorded.

---

**MENU** →  (**Setup**) → **[Select REC Folder]** → **desired folder**.

---

### Note

- You cannot select the folder when [Folder Name] is set to [Date Form].
- If [Recording Mode] is set to other than [Standard], you may only select the common folder on the both memory cards. If there is no common folder, you can make one using [New Folder] (page 219).

# Camera settings

## Pwr Save Start Time

Sets time intervals to automatically switch to power save mode when you are not performing operations to prevent wearing down the battery pack. To return to shooting mode, perform an operation such as pressing the shutter button halfway down.

---

**MENU** →  (**Setup**) → [**Pwr Save Start Time**] → **desired setting.**  
**30 Min/5 Min/2 Min/1 Min/10 Sec**

---

### Note

- Turn off the product when you do not use it for a long time.
- The power save function is not activated when power is being supplied via USB, when playing back slideshows, when recording movies, or when connected to a computer or TV.

## Remote Ctrl

You can operate this product and shoot images using the SHUTTER button, 2SEC button (2 second delay shutter), and START/STOP button (or Movie button (RMT-DSLR2 only)) on the Wireless Remote Commander RMT-DSLR1 (sold separately) and RMT-DSLR2 (sold separately). Refer also to the operating instructions for the Wireless Remote Commander.

---

**MENU** →  (**Setup**) → [**Remote Ctrl**] → **desired setting.**

**On:** Allows remote commander operation.

**Off:** Does not allow remote commander operation.

---

### Note

- The lens or lens hood may block the remote sensor that receive the signals. Use the remote commander in the position from which the signal can reach the product.
- When [Remote Ctrl] is set to [On], the product does not switch to power save mode. Set [Off] after using a remote commander.

## HDMI Settings

### HDMI Resolution

When you connect the product to a High Definition (HD) TV with HDMI terminals using an HDMI cable (sold separately), you can select HDMI Resolution to output images to the TV.

**MENU** →  (Setup) → [HDMI Settings] → [HDMI Resolution] → **desired setting**.

**Auto:** The product automatically recognizes an HD TV and sets the output resolution.

**2160p/1080p:** Outputs signals in 2160p/1080p.

**1080p:** Outputs signals in HD picture quality (1080p).

**1080i:** Outputs signals in HD picture quality (1080i).



### Note

- If the images are not displayed properly using the [Auto] setting, select either [1080i], [1080p] or [2160p/1080p], based on which TV is to be connected.

### **24p/60p Output (Only for 1080 60i compatible models)**

Set 1080/24p or 1080/60p as the HDMI output format when  Record Setting] is set to [24p 24M (FX)], [24p 17M (FH)] or [24p 50M].

① **MENU** →  (Setup) → [HDMI Settings] → [HDMI Resolution] → [1080p] or [2160p/1080p].

② **MENU** →  (Setup) → [HDMI Settings] →  **24p/60p Output**] → **desired setting**.

**60p:** Movies are output as 60p.

**24p:** Movies are output as 24p.

#### Note

- Steps ① and ② can be set in either order.
- When [TC Record Setting] is set to other than [24p 24M (FX)], [24p 17M (FH)], or [24p 50M], this setting is canceled, and HDMI video is output according to the [HDMI Resolution] settings.

## HDMI Info. Display

Selects whether to display the shooting information when this product and the TV are connected using an HDMI cable (sold separately).

**MENU** →  (Setup) → [HDMI Settings] → [HDMI Info. Display] → desired setting.

**On:** Displays the shooting information on the TV.

The recorded image and the shooting information are displayed on the TV, while nothing is displayed on the camera's monitor.

**Off:** Does not display the shooting information on the TV.

Only the recorded image is displayed on the TV, while the recorded image and the shooting information are displayed on the camera's monitor.

#### Note

- When this product is connected to a 4K-compatible TV, [Off] is selected automatically.

## TC Output

Sets whether or not to layer the TC (time code) information on the output signal via the HDMI terminal when outputting the signal to other professional-use devices.

This function layers the time code information on the HDMI output signal. The product sends the time code information as digital data, not as an image displayed on the screen. The connected device can then refer to the digital data to recognize the time data.

**MENU** →  (Setup) → [HDMI Settings] → [TC Output] → desired setting.

**On:** Time code is output to other devices.

**Off:** Time code is not output to other devices.

## Note

- When [TC Output] is set to [On], the image may not be output properly to the TV or recording device. In such cases, set [TC Output] to [Off].

## REC Control

If you connect the camera to an external recorder/player, you can remotely command the recorder/player to start/stop recording using the camera.



**MENU** →  (**Setup**) → **[HDMI Settings]** → **[REC Control]** → **desired setting.**

**On:**  **STBY** The camera can send a recording command to an external recorder/player.

 **REC** The camera is sending a recording command to an external recorder/player.

**Off:** The camera is not able to send a command to an external recorder/player to start/stop recording.

## Note

- Available for external recorders/players compatible with [REC Control].
- When you use the [REC Control] function, set the shooting mode to  (Movie).
- When [TC Output] is set to [Off], you cannot use the [REC Control] function.
- Even when  **REC** is displayed, the external recorder/player may not work properly depending on the settings or status of the recorder/player. Check if the external recorder/player works properly before use.

## CTRL FOR HDMI

When connecting this product to a "BRAVIA" Sync-compatible TV using an HDMI cable (sold separately), you can operate this product by aiming the TV remote control at the TV.

- ① **MENU** →  (Setup) → [HDMI Settings] → [CTRL FOR HDMI] → **desired setting.**

**On:** You can operate this product with a TV's remote control.

**Off:** You cannot operate this product with a TV's remote control.

- ② **Connect this product to a "BRAVIA" Sync-compatible TV.**

The input of the TV is switched automatically and images on this product are displayed on the TV screen.

- ③ **Press the SYNC MENU button of the TV's remote control.**

- ④ **Operate this product using the TV's remote control.**

### Note

- If you connect this product to a TV using an HDMI cable, available menu items are limited.
- [CTRL FOR HDMI] is available only with a "BRAVIA" Sync-compatible TV. Also, the SYNC MENU operation differs depending on the TV you are using. For details, refer to the operating instructions supplied with the TV.
- If the product performs unwanted operations in response to the TV remote control when the product is connected to another manufacturer's TV using an HDMI connection, select MENU →  (Setup) → [HDMI Settings] → [CTRL FOR HDMI] → [Off].

## USB Power Supply

Sets whether to supply power via the micro USB cable when the product is connected to a computer or an USB device.

**MENU** →  (**Setup**) → [**USB Power Supply**] → **desired setting**.

**On:** Power is supplied to the product via a micro USB cable when the product is connected to a computer, etc.

**Off:** Power is not supplied to the product via a micro USB cable when the product is connected to a computer, etc. If you use the supplied AC Adaptor, power will be supplied even when [Off] is selected.

### Note

- Insert the battery pack into the product to supply power via USB cable.

## PC Remote Settings

### Still Img. Save Dest.

Sets whether to save still images stored in both the camera and the computer during PC Remote shooting. This setting is useful when you want to check recorded images on the camera without leaving the camera.

\* PC Remote: Uses "Remote Camera Control" (page 204) to control this product from the computer, including such functions as shooting and storing images on the computer.

**MENU** →  (**Setup**) → [**PC Remote Settings**] → [**Still Img. Save Dest.**] → **desired setting**.

**PC Only:** Saves still images only on the computer.

**PC + Camera:** Saves still images on the computer and the camera.

## Note

- During PC Remote shooting, you cannot change settings for [Still Img. Save Dest.]. Adjust the settings before you start shooting.
- If you insert a memory card that is not recordable, you cannot shoot still images even if you select [PC + Camera].
- If you select [PC + Camera] and you have not inserted a memory card into the camera, you cannot release the shutter even if [Release w/o Card] is set to [Enable].
- During PC Remote shooting, [Recording Mode] is locked to [Standard] and cannot be changed.
- While you are playing back still images on the camera, you cannot shoot using PC Remote.

## RAW + J PC Save Img

Selects the file type for images to be transferred to the computer in PC Remote shooting.

When shooting still images using PC Remote, the application on the computer does not display the image until the image has been completely transferred. When performing RAW + JPEG shooting, you can accelerate the display processing speed by transferring only JPEG images instead of transferring both RAW and JPEG images.

\* PC Remote: Uses "Remote Camera Control" (page 204) to control this product from the computer, including such functions as shooting and storing images on the computer.

**MENU** →  (**Setup**) → **[PC Remote Settings]** → **[RAW + J PC Save Img]** → **desired setting.**

**RAW & JPEG:** Transfers both RAW and JPEG files to the computer.

**JPEG Only:** Transfers only JPEG files to the computer.

**RAW Only:** Transfers only RAW files to the computer.

## Note

- [RAW + J PC Save Img] can be set only when [ Quality] is set to [RAW & JPEG].
- During PC Remote shooting, [Recording Mode] is locked to [Standard] and cannot be changed.



# Initializing the camera

## Setting Reset

Resets the product to the default settings. Even if you perform [Setting Reset], the recorded images are retained.

---

**MENU** →  (**Setup**) → **[Setting Reset]** → **desired setting**.

**Camera Settings Reset:** Initializes the main shooting settings to the default settings.

**Initialize:** Initializes all the settings to the default settings.

---

### Note

- Be sure not to eject the battery pack while resetting.
- The value set with [AF Micro Adj.] will not be reset even when [Camera Settings Reset] or [Initialize] is performed.

## Using the Wi-Fi/One-touch (NFC)/Bluetooth/wired LAN functions

You can perform the following operations using the camera's Wi-Fi, NFC One-touch, and Bluetooth functions.

- Saving images to a computer
- Transferring images from the camera to a smartphone
- Using a smartphone as a remote control for the camera
- Viewing still images on a TV
- Recording location information from a smartphone to images

For details, refer to the "Help Guide" (page 2).

### Installing PlayMemories Mobile

PlayMemories Mobile is required to connect the camera and a smartphone. If PlayMemories Mobile is already installed on your smartphone, be sure to update it to the latest version.

For details on PlayMemories Mobile, refer to the support page (<http://www.sony.net/pmm/>).



#### Note

- To use the camera's NFC One-touch function, an NFC-enabled Android smartphone or tablet is required.
- The Wi-Fi functions introduced in this manual are not guaranteed to operate on all smartphones or tablets.
- The Wi-Fi functions of this camera are not available when connected to a public wireless LAN.
- Depending on future version upgrades, the operational procedures or screen displays are subject to change without notice.

## Transferring images to the FTP server

You can use the camera's Wi-Fi function or wired LAN to transfer images to the FTP server.

For details, refer to the "FTP Help Guide."

[http://rd1.sony.net/help/di/ftp/h\\_zz/](http://rd1.sony.net/help/di/ftp/h_zz/)



- Basic knowledge of FTP servers is required.

# Connecting the camera and a smartphone

## Using a smartphone as a remote control for the camera

With PlayMemories Mobile, you can shoot images while checking the shooting range of the camera on the monitor of a smartphone.

---



**1** MENU →  (Network) → [Ctrl w/ Smartphone] → [Ctrl w/ Smartphone], then select [On].

---

**2** Set up the camera and smartphone by following the procedure below.

---



### ■ To establish a one-touch connection with an NFC-enabled Android smartphone

- ① Activate the NFC function of the smartphone.
- ② Switch the camera to the shooting mode.
- ③ Touch the  (N mark) on the camera to the  (N mark) on the smartphone for 1-2 seconds until PlayMemories Mobile launches.

#### Note

- If you cannot connect the camera to the smartphone using the NFC function, follow the procedure under “To establish a Wi-Fi connection with a smartphone using a QR code.”

## ■ To establish a Wi-Fi connection with a smartphone using a QR code

- ① Select MENU →  (Network) → [Ctrl w/ Smartphone] →  Connection Info., to display the QR code on the monitor of the camera.



- ② Launch PlayMemories Mobile on the smartphone, and select [Scan QR Code of the Camera].
- ③ Scan the QR code.

Follow the steps below only if using an iPhone or iPad.

- ④ Install the profile by following the instructions on the iPhone or iPad screen.
- ⑤ On the "Home" screen of the iPhone or iPad, select [Settings] → [Wi-Fi].
- ⑥ Select the SSID displayed on the camera.
- ⑦ Return to the "Home" screen of the iPhone or iPad and launch PlayMemories Mobile.

### Hint

- Once the QR code has been read, this product's SSID (DIRECT-xxxx) and password are registered to the smartphone. This enables you to easily connect the smartphone to the product via Wi-Fi at a later date by selecting the SSID.

### Note

- If you cannot connect this product to a smartphone using the NFC function or QR code, use the SSID and password. For detailed instructions, refer to the "Help Guide."

## Transferring images from the camera to a smartphone

You can transfer still images and movies shot in the MP4 file format. However, images that are not saved on the camera's memory card cannot be transferred.



---

### 1 On the camera, play back an image that you want to transfer to the smartphone.



---

### 2 Connect the camera to the smartphone.

Images shot with the camera are transferred to the smartphone.

- To establish a one-touch connection with an NFC-enabled Android smartphone, touch the  (N mark) on the smartphone to the  (N mark) on the camera (page 192).
  - To establish a Wi-Fi connection with the smartphone using a QR code, select MENU →  (Network) → [Send to Smartphone] and display the QR code on the monitor of the camera, then scan the QR code using PlayMemories Mobile on the smartphone.
  - The transferred images are saved to a gallery or album on the Android, or to an album on the iPhone or iPad.
- 

#### Note

- If you scan the QR code displayed under MENU →  (Network) → [Ctrl w/ Smartphone] → , the function for using the smartphone as a remote control for the camera will be activated (page 193). To transfer images, select [Send to Smartphone] and display the QR code.

# Connecting the camera to a wireless access point

Connect the camera to your wireless access point. Before starting the procedure, make sure you have the SSID (name of the access point) and password of your wireless access point with you.

**1** MENU →  (Network) → [Wi-Fi Settings] → [Access Point Set.].

**2** Use the control wheel to select the access point to which you want to connect. Press the center of the control wheel and enter the password for the wireless access point, then select [OK].

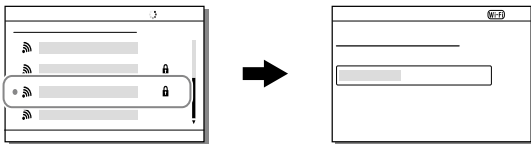

## Note

- If a connection is not established, see the wireless access point operating instructions or contact the administrator of the access point.  
To save images to a computer, install PlayMemories Home on your computer.

PlayMemories Home  
<http://www.sony.net/pm/>

# Recording location information to captured images

You can use the application PlayMemories Mobile to obtain location information from a smartphone that is connected with your camera using Bluetooth communication. You can record the obtained location information when shooting images.

## Preparation in advance

To use the location information linking function of the camera, the application PlayMemories Mobile is required.

If "Location Information Linkage" is not displayed on the top page of PlayMemories Mobile, you need to perform the following steps beforehand.

---

### 1 Install PlayMemories Mobile on your smartphone.

- You can install PlayMemories Mobile from the application store of your smartphone. If you have already installed the application, update it to the latest version.
- 

### 2 Transfer a pre-recorded image to your smartphone using the [Send to Smartphone] function of the camera.

- For detailed instructions, please refer to the "Help Guide."
  - After you transfer an image recorded using the camera to your smartphone, "Location Information Linkage" will appear on the top page of PlayMemories Mobile.
-



## Operating procedure

: Operations performed on the smartphone

: Operations performed on the camera

### 1 : Confirm that the Bluetooth function of your smartphone is activated.

- Do not perform the Bluetooth pairing operation on the smartphone setting screen. In steps 2 to 7, the pairing operation is performed using the camera and the application PlayMemories Mobile.
- If you accidentally perform the pairing operation on the smartphone setting screen in step 1, cancel the pairing and then perform the pairing operation by following steps 2 through 7 using the camera and the application PlayMemories Mobile.

### 2 : On the camera, select MENU → (Network) → [Bluetooth Settings] → [Bluetooth Function] → [On].

### 3 : On the camera, select MENU → (Network) → [Bluetooth Settings] → [Pairing].

### 4 : Launch PlayMemories Mobile on your smartphone and tap "Location Information Linkage."

- If "Location Information Linkage" is not displayed, follow the steps in "Preparation in advance" above.

### 5 : Activate [Location Information Linkage] on the [Location Information Linkage] setting screen of PlayMemories Mobile.

### 6 : Follow the instructions on the [Location Information Linkage] setting screen of PlayMemories Mobile, and then select your camera from the list.

---

## 7 : Select [OK] when a message is displayed on the monitor of the camera.

- Pairing of the camera and PlayMemories Mobile is complete.
- 

## 8 : On the camera, select MENU → (Network) → [Loc. Info. Link Set.] → [Location Info. Link] → [On].

-  (obtaining location information icon) will be displayed on the monitor of the camera. Location information obtained by your smartphone using GPS, etc., will be recorded when shooting images.
- 

## Icons displayed when obtaining the location information

 (Obtaining location information): The camera is obtaining the location information.

 (Location information cannot be obtained): The camera cannot obtain the location information.

 (Bluetooth connection available): Bluetooth connection with the smartphone is established.

 (Bluetooth connection unavailable): Bluetooth connection with the smartphone is not established.

### Hint

- Location information can be linked when PlayMemories Mobile is running on your smartphone even if the smartphone monitor is off.
- When PlayMemories Mobile is not operating, such as when the smartphone is restarted, launch PlayMemories Mobile to resume location information linking.
- In the application PlayMemories Home, you can view images on a map by importing images with location information to your computer. For details, refer to Help for PlayMemories Home.
- If the location information linking function does not work properly, see the following notes and perform pairing again.
  - Confirm that the Bluetooth function of your smartphone is activated.
  - Confirm that the camera is not connected with other devices using the Bluetooth function.
  - Confirm that [Airplane Mode] for the camera is set to [Off] (page 215).
  - Delete the pairing information for the camera registered in PlayMemories Mobile.
  - Execute [Reset Network Set.] of the camera.
- For more detailed video instructions, refer to the following support page.  
<http://www.sony.net/pmm/btg/>

## Note

- When you initialize the camera, the pairing information is also deleted. To perform pairing again, delete the pairing information for the camera registered in PlayMemories Mobile before trying again.
- The location information will not be recorded when it cannot be obtained, such as when the Bluetooth connection is disconnected.
- The camera can be paired with up to 15 Bluetooth devices, but can link the location information with that of only one smartphone. If you want to link the location information with that of a different smartphone, turn off [Location Information Linkage] in PlayMemories Mobile on the smartphone that is currently linked.
- If the Bluetooth connection is unstable, remove any obstacles, such as people or metal objects from between the camera and the paired smartphone.
- When pairing the camera and your smartphone, be sure to use the [Location Information Linkage] menu on PlayMemories Mobile.

## Supported smartphones

- Android smartphones: Android 5.0 or later and compatible with Bluetooth 4.0 or later\*
  - iPhone/iPad: iPhone 4S or later/iPad 3rd generation or later
- \* As of April 2017. For the latest information, refer to the support site.  
\* For the Bluetooth version, refer to the website for your smartphone.

## Connecting the camera to a computer

### Selecting the appropriate USB connection method

Selects the USB connection method when this product is connected to a computer, etc.

---

**MENU** →  (Setup) → [USB Connection] → **desired setting.**

**Auto:** Establishes a Mass Storage or MTP connection automatically, depending on the computer or other USB devices to be connected. Windows 7, Windows 8.1, or Windows 10 computers are connected in MTP, and their unique functions are enabled for use.

**Mass Storage:** Establishes a Mass Storage connection between this product, a computer, and other USB devices.

**MTP:** Establishes an MTP connection between this product, a computer, and other USB devices. Windows 7, Windows 8.1, or Windows 10 computers are connected in MTP, and their unique functions are enabled for use.

- The memory card in memory card slot 1 is the connection target.

**PC Remote:** Uses "Remote Camera Control" (page 204) to control this product from the computer, including such functions as shooting and storing images on the computer.

---

#### Note

- It may take some time to make the connection between this product and a computer when [USB Connection] is set to [Auto].

## Connecting to a computer

**1** Insert a fully charged battery pack into the camera.

**2** Turn on the camera and the computer.

**3** Check that [USB Connection] under  (Setup) is set to [Mass Storage].

**4** Connect the camera to the computer using the micro USB cable (supplied).

- When you connect the camera to the computer for the first time, the procedure for recognizing the camera may start automatically on the computer. Wait until the procedure is finished.
- If you connect the product to your computer using the micro USB cable when [USB Power Supply] is set to [On], power is supplied from your computer. (Default setting: [On])

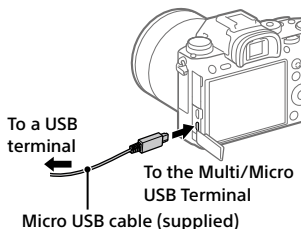

## Disconnecting the camera from the computer

Perform steps 1 and 2 below before performing the following operations:

- Disconnecting the micro USB cable.
- Removing a memory card.
- Turning off the product.

---

**1** Click  (Safely Remove Hardware and Eject Media) in the taskbar.

---

**2** Click the displayed message.

---

### Note

- On Mac computers, drag and drop the memory card icon or the drive icon into the “Trash” icon. The camera will be disconnected from the computer.
- On Windows 7/Windows 8 computers, the disconnection icon may not appear. In that case, you can skip the steps above.
- Do not remove the micro USB cable from the camera while the access lamp is lit. The data may be damaged.

# Introduction to computer software

We offer the following computer software to enhance your enjoyment of photos/movies. Access one of the following URLs using your Internet browser and then download the software by following the onscreen instructions.

If one of these software is already installed on your computer, update it to the latest version before use.

## **Windows:**

<http://www.sony.co.jp/imsoft/Win/>

## **Mac:**

<http://www.sony.co.jp/imsoft/Mac/>

You can check the recommended operating environment for the software from the following URL:

<http://www.sony.net/pcenv/>

## **PlayMemories Home**

PlayMemories Home allows you to import still images and movies to your computer and view or use them.

You need to install PlayMemories Home to import XAVC S movies or AVCHD movies to your computer.

You can access the download website directly from the following URL:

<http://www.sony.net/pm/>

- When you connect the camera to your computer, new functions may be added to PlayMemories Home. Connecting the camera to your computer is therefore recommended even if PlayMemories Home has already been installed on the computer.

## **Image Data Converter**

You can develop and edit RAW images using various adjustment functions like tone curve and sharpness.

## Remote Camera Control

With Remote Camera Control, you can change the camera settings or release the shutter from a computer connected via a USB cable.

To use Remote Camera Control, first select MENU →  (Setup) → [USB Connection] → [PC Remote], then connect the camera to a computer via a USB cable.



## Using MENU items

You can change settings related to all the camera operations including shooting, playback, and operating method. You can also execute camera functions from the MENU.

- 1 Press the MENU button to display the menu screen.**

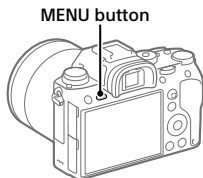

- 2 Select the desired setting you want to adjust using the top/bottom/left/right sides of the control wheel or by turning the control wheel, and then press the center of the control wheel.**

- Select an icon at the top of the screen and press the left/right side of the control wheel to move to another MENU item.

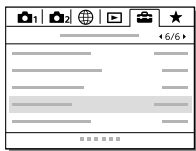







- 3 Select the desired setting value, and press the center to confirm your selection.**







# List of MENU items







For details on each MENU items, refer to the reference page in the last column or the Help Guide.

## 1 (Camera Settings 1)



Red tab

Quality/Image Size		
 <b>Quality</b>	Sets the image quality for still images. ([RAW] / [Fine], etc.)	93
 <b>RAW File Type</b>	Selects the file type for RAW images.	Help Guide
 <b>Image Size</b>	Selects the size of still images. (L / M / S)	92
 <b>Aspect Ratio</b>	Selects the aspect ratio for still images.	93
<b>APS-C/Super 35mm</b>	Sets whether to record in APS-C-equivalent size for still images and Super 35 mm-equivalent size for movies.	95
 <b>Long Exposure NR</b>	Sets noise reduction processing for shots with a shutter speed of 1 second or longer.	129
 <b>High ISO NR</b>	Sets noise reduction processing for high-sensitivity shooting.	130
 <b>Color Space</b>	Changes the color space (range of reproducible colors).	126
<b>Lens Comp.</b>	Selects the type of lens compensation.	Help Guide
Shoot Mode/Drive		
<b>Self-timer Type</b>	When shooting with the self-timer, sets how many seconds elapse from when you press the shutter button until when the image is recorded and how many images are recorded.	Help Guide

<b>Bracket Settings</b>	Sets self-timer shooting in bracket mode, bracket type, shooting order for exposure bracketing, and white balance bracketing.	89
 <b>Recall</b>	Calls up settings pre-registered to [  Memory].	103
 <b>Memory</b>	Registers the desired modes and camera settings.	167
<b>Reg Cust Shoot Set</b>	Assign functions to the custom key to recall when shooting.	168
<b>AF</b>		
<b>Priority Set in AF-S</b>	Sets the timing of the shutter release when [Focus Mode] is set to [Single-shot AF] or [DMF] with a still subject.	65
<b>Priority Set in AF-C</b>	Sets the timing of the shutter release when [Focus Mode] is set to [Continuous AF] with a moving subject.	65
<b>Focus Area</b>	Selects the area of focus. ([Wide] / [Flexible Spot], etc.)	53
<b>Focus Settings</b>	Allows you to focus using the front dial, rear dial or control wheel.	Help Guide
 <b>Swt. V/H AF Area</b>	Sets whether to adjust the [Focus Area] and the position of the focusing frame based on the camera's position (horizontal or vertical).	57
 <b>AF Illuminator</b>	Sets the AF illuminator, which provides light to aid focusing in dark scenes.	66
<b>Center Lock-on AF</b>	Sets the function to track a subject and continue focusing when pressing the center of the control wheel in the shooting screen.	61
 <b>AF Track Sens</b>	Sets the AF tracking sensitivity for the still image mode.	Help Guide

 <b>AF System</b>	Sets the auto focus method when an LA-EA1/LA-EA3 Mount Adaptor (sold separately) is attached.	68
 <b>AF w/ shutter</b>	Sets whether to perform auto focusing when the shutter button is pressed halfway down. This is useful when you want to adjust the focus and exposure separately.	Help Guide
 <b>Pre-AF</b>	Sets whether or not to perform auto focus before the shutter button is half pressed.	64
 <b>Eye-Start AF</b>	Sets whether to use auto focus when you look through the viewfinder if an LA-EA2/LA-EA4 Mount Adaptor (sold separately) is attached.	Help Guide
 <b>AF Area Regist.</b>	Sets whether to move the focusing frame to a preassigned position when shooting still images.	63
 <b>Del. Reg. AF Area</b>	Deletes the focusing frame position information that was registered using [  AF Area Regist.].	Help Guide
<b>AF Area Auto Clear</b>	Sets whether the focus area is displayed all the time or disappears automatically shortly after focusing.	Help Guide
<b>Disp. cont. AF area</b>	Sets whether or not to display the focus area in [Continuous AF] mode.	Help Guide
<b>AF Micro Adj.</b>	Finely adjusts the autofocused position, when using the LA-EA2 or LA-EA4 Mount Adaptor (sold separately).	67
<b>Exposure</b>		
<b>Exposure Comp.</b>	Compensates for the brightness of the entire image.	106
<b>Reset EV Comp.</b>	Sets whether to maintain the exposure value set using [Exposure Comp.] when you turn off the power when the exposure compensation dial position is set to "0."	Help Guide









<b>ISO</b>	Sets the ISO sensitivity. ([ISO AUTO], etc.)	115
<b>ISO AUTO Min. SS</b>	Sets the slowest shutter speed at which ISO sensitivity will start to change in [ISO AUTO] mode.	116
<b>Metering Mode</b>	Selects the method for measuring brightness. ([Multi] / [Spot], etc.)	108
<b>Spot Metering Point</b>	Sets whether to coordinate the spot metering point with the focus area when [Focus Area] is set to [Flexible Spot] or [Expand Flexible Spot].	109
<b>Exposure step</b>	Selects the size of the increment step for shutter speed, aperture, and exposure compensation values.	Help Guide
 <b>AEL w/ shutter</b>	Sets whether to lock the exposure when the shutter button is pressed halfway down. This is useful when you want to adjust the focus and exposure separately.	Help Guide
<b>Exposure Std. Adjust</b>	Adjusts the standard for the correct exposure value for each metering modes.	Help Guide
<b>Flash</b>		
<b>Flash Mode</b>	Sets the flash settings.	133
<b>Flash Comp.</b>	Adjusts the intensity of flash output.	134
<b>Exp. comp. set</b>	Sets whether to reflect exposure compensation value to flash compensation.	Help Guide
<b>Red Eye Reduction</b>	Reduces the red-eye phenomenon when using flash.	Help Guide
<b>Color/WB/Img. Processing</b>		
<b>White Balance</b>	Corrects the tone effect of the ambient light to shoot whitish objects in a white tone. ([Auto] / [Daylight], etc.)	120



<b>Priority Set in AWB</b>	Selects which tone to prioritize when shooting under lighting conditions such as incandescent light with [White Balance] set to [Auto].	Help Guide
<b>DRO/Auto HDR</b>	Analyzes the contrast of light and shadow between the subject and the background by dividing the image into small areas, and creates an image with the optimal brightness and gradation.	112
<b>Creative Style</b>	Selects the desired image processing. You can also adjust contrast, saturation, and sharpness. ([Vivid] / [Portrait], etc.)	123
<b>Picture Effect</b>	Shoots images with a texture unique to the selected effect. ([Toy Camera] / [Rich-tone Mono.], etc.)	Help Guide
<b>Focus Assist</b>		
<b>Focus Magnifier</b>	Enlarges the image before shooting so that you can check the focus.	71
<b>Focus Magnif. Time</b>	Sets the length of time the image will be shown in an enlarged form.	Help Guide
 <b>Initial Focus Mag.</b>	Sets the initial magnification scale when using [Focus Magnifier].	Help Guide
 <b>AF in Focus Mag.</b>	Sets whether or not to autofocus when an enlarged image is being displayed. While the enlarged image is being displayed, you can focus within a smaller area than the flexible spot.	60
 <b>MF Assist</b>	Displays an enlarged image when focusing manually.	72
<b>Peaking Level</b>	Enhances the outline of in-focus areas with a specific color when focusing manually.	73
<b>Peaking Color</b>	Sets the color used for the peaking function.	Help Guide

Face Detection/Shoot Assist		
<b>Face Detection</b>	Sets whether to detect faces and automatically adjust various settings such as focus, exposure, image processing, and flash.	131
<b>Face Registration</b>	Registers or changes the person to be given priority when focusing.	Help Guide

## 2 (Camera Settings 2)

Purple tab

Movie		
 <b>Exposure Mode</b>	Selects the exposure mode to suit your subject or effect.	104
 <b>S&amp;Q Exposure Mode</b>	Sets the exposure mode when shooting slow-motion/quick-motion movies.	105
 <b>File Format</b>	Selects the movie file format. ([XAVC S 4K] / [AVCHD], etc.)	142
 <b>Record Setting</b>	Selects the bit rate and frame rate for the movie size.	143
 <b>S&amp;Q S&amp;Q Settings</b>	Changes the settings for slow-motion and quick-motion movie shooting.	147
<b>Dual Video REC</b>	Sets whether to simultaneously record an XAVC S movie and MP4 movie or an AVCHD movie and MP4 movie.	Help Guide
 <b>AF drive speed</b>	Switches focusing speed when using autofocus in movie mode.	Help Guide
 <b>AF Track Sens</b>	Sets the AF tracking sensitivity for the movie mode.	Help Guide
 <b>Auto Slow Shut.</b>	Sets the function that automatically adjusts the shutter speed following the brightness of the environment in movie mode.	Help Guide
<b>Audio Recording</b>	Sets whether to record audio when shooting a movie.	149

<b>Audio Rec Level</b>	Adjusts the audio recording level during movie recording.	150
<b>Audio Level Display</b>	Sets whether to display the audio level.	Help Guide
<b>Audio Out Timing</b>	Sets the timing of audio output during the movie recording.	Help Guide
<b>Wind Noise Reduct.</b>	Reduces wind noise during movie recording.	Help Guide
 <b>Marker Display</b>	Sets whether to display markers on the monitor when recording movies.	151
 <b>Marker Settings</b>	Sets which markers to display on the monitor when recording movies.	151
<b>Video Light Mode</b>	Sets the illumination setting for the HVL-LBPC LED light (sold separately).	Help Guide
<b>Movie w/ shutter</b>	Records movies using the shutter button.	141
<b>Shutter/SteadyShot</b>		
 <b>Shutter Type</b>	Sets whether to shoot with a mechanical shutter or an electronic shutter.	74
<b>e-Front Curtain Shut.</b>	Sets whether to use the electronic front curtain shutter function.	78
<b>Release w/o Lens</b>	Sets whether to release the shutter when the lens is not attached.	Help Guide
<b>Release w/o Card</b>	Sets whether to release the shutter when a memory card is not inserted.	Help Guide
<b>SteadyShot</b>	Sets whether to activate SteadyShot for shooting.	127
<b>SteadyShot Settings</b>	Sets SteadyShot settings.	127
<b>Zoom</b>		
<b>Zoom</b>	Sets the zoom scale for zoom functions other than the optical zoom.	118
<b>Zoom Setting</b>	Sets whether to use the Clear Image Zoom and Digital Zoom when zooming.	119



<b>Zoom Ring Rotate</b>	Assigns the zoom in/out to the rotational direction of the zoom lens. This function is only available with a power zoom lens that is compatible with this function.	Help Guide
<b>Display/Auto Review</b>		
<b>DISP Button</b>	Sets the type of information to be displayed on the monitor or in the viewfinder when the DISP button is pressed.	37
<b>FINDER/MONITOR</b>	Sets the method for switching the display between the electronic viewfinder and the monitor.	176
 <b>Finder Frame Rate</b>	Sets the frame rate for the viewfinder when shooting still images.	177
<b>Zebra</b>	Displays stripes to adjust brightness.	111
<b>Grid Line</b>	Displays grid lines for adjusting the image composition.	Help Guide
<b>Exposure Set. Guide</b>	Sets the guide displayed when exposure settings are changed in the shooting screen.	Help Guide
<b>Live View Display</b>	Sets whether to reflect settings such as exposure compensation in screen display.	Help Guide
<b>Shoot. Start Disp.</b>	Sets whether to let the screen black out when shooting the first image during blackout-free shooting.	78
<b>Shoot. Timing Disp.</b>	Sets the method for displaying the shutter release timing on the screen during blackout-free shooting.	77
<b>Cont. Shoot. Length</b>	Sets whether to display an indicator of the remaining time for which continuous shooting can be performed at the same shooting speed.	81
<b>Auto Review</b>	Sets auto review to display the captured image after shooting.	174



<b>Custom Operation</b>		
<b>Custom Key (Shoot.)</b>	Assigns functions to the various keys so that you can perform operations more quickly by pressing the keys when shooting images.	170
<b>Custom Key (PB)</b>	Assigns functions to the keys so that you can perform operations more quickly by pressing the keys when playing back images.	170
<b>Function Menu Set.</b>	Customizes the functions displayed when the Fn (Function) button is pressed.	171
<b>Dial Setup</b>	Sets the functions of the front and rear control dials when the exposure mode is set to M. Dials can be used for adjusting shutter speed and aperture.	Help Guide
<b>Dial Ev Comp</b>	Sets whether to compensate the exposure with the front or rear dial.	Help Guide
<b>MOVIE Button</b>	Enables or disables for the MOVIE button.	Help Guide
<b>Lock Operation Parts</b>	Sets whether to disable the multi-selector, control wheel, or front and rear dials temporarily when the Fn button is pressed and held down.	Help Guide
<b>Audio signals</b>	Selects whether the electronic shutter makes a sound or the camera beeps during auto focus and self-timer operations.	Help Guide

## **(Network)**



**Green tab**

<b>Send to Smartphone</b>	Transfers images to display on a smartphone.	Help Guide
<b>Send to Computer</b>	Backs up images by transferring them to a computer connected to a network.	Help Guide

<b>FTP Transfer Func.</b>	Sets image transfer using FTP and executes it. * Basic knowledge of FTP server is required.	191
<b>View on TV</b>	Allows you to view images on a network-enabled TV.	Help Guide
<b>Ctrl w/ Smartphone</b>	Allows you to use a smartphone as the remote controller for the camera and shoot still images/movies. Still images/movies shot via remote control are sent to the smartphone from the camera.	Help Guide
<b>Airplane Mode</b>	Disables wireless communications from the device such as Wi-Fi, NFC, and Bluetooth function.	Help Guide
<b>Wi-Fi Settings</b>	Allows you to register your access point and check or change the Wi-Fi connection information.	Help Guide
<b>Bluetooth Settings</b>	Controls the settings for connecting the camera with a smartphone via a Bluetooth connection.	197
<input type="checkbox"/> <b>Loc. Info. Link Set.</b>	Obtains location information from the paired smartphone and records it to captured images.	197
<b>Wired LAN Setting</b>	Sets the wired LAN.	Help Guide
<b>Edit Device Name</b>	Changes the device name under Wi-Fi Direct, etc.	Help Guide
<b>Imp Root Certificate</b>	Imports a root certificate to the camera.	Help Guide
<b>Reset Network Set.</b>	Resets all the network settings.	Help Guide

<b>Delete</b>	Deletes an image.	162
<b>View Mode</b>	Plays back images from a specified date or specified folder of still images and movies.	158
<b>Image Index</b>	Displays multiple images at the same time.	157
<b>Display Rotation</b>	Sets the playback orientation for images shot vertically.	155
<b>Select PB Media</b>	Selects the memory card slot of the memory card to be played back.	159
<b>Copy</b>	Allows you to copy images from the memory card in the memory card slot designated in [Select PB Media] to the memory card in the other slot.	159
<b>Slide Show</b>	Plays a slide show.	160
<b>Rotate</b>	Rotates the image.	Help Guide
 <b>Enlarge Image</b>	Enlarges the playback images.	154
 <b>Enlarge Init. Mag.</b>	Sets the initial magnification scale when playing back enlarged images.	Help Guide
 <b>Enlarge Initial Pos.</b>	Sets the initial magnification area when playing back enlarged images.	Help Guide
<b>Protect</b>	Protects recorded images against accidental erasure.	161
<b>Specify Printing</b>	Specifies in advance on the memory card which still images to print out later.	Help Guide
<b>Photo Capture</b>	Captures a chosen scene in a movie to save as a still image.	157

<b>Monitor Brightness</b>	Adjusts the brightness of the screen.	Help Guide
<b>Viewfinder Bright.</b>	Sets the brightness of the electronic viewfinder.	Help Guide
<b>Finder Color Temp.</b>	Sets the color temperature of the viewfinder.	Help Guide
<b>Volume Settings</b>	Sets the volume for movie playback.	Help Guide
<b>Delete confirm.</b>	Sets whether [Delete] or [Cancel] is preselected in the delete confirmation screen.	Help Guide
<b>Pwr Save Start Time</b>	Sets the time intervals to automatically switch to power save mode.	182
<b>Auto Pwr OFF Temp.</b>	Sets the camera temperature at which the camera turns off automatically during shooting. When shooting in hand-held mode, set to [Standard].	Help Guide
<b>NTSC/PAL Selector<sup>1</sup></b>	Changes the TV format of the device so that you can shoot in a different movie format.	Help Guide
<b>Cleaning Mode</b>	Starts the cleaning mode to clean the image sensor.	238
<b>Touch Operation</b>	Sets whether or not to activate the touch operation of the monitor.	90
<b>Demo Mode</b>	Sets demonstration playback of movies to on or off.	Help Guide

<b>TC/UB Settings</b>	Sets the time code (TC) and user bit (UB). * This function is for skilled movie creators.	Help Guide
<b>Remote Ctrl</b>	Sets whether to use the infrared remote control.	182
<b>HDMI Settings</b>	Sets the HDMI settings.	183
 <b>4K Output Sel.</b>	Sets how to record and output 4K movies via HDMI when the camera is connected to an external recorder/ player that supports 4K.	152
<b>USB Connection</b>	Sets the USB connection method.	200
<b>USB LUN Setting</b>	Enhances compatibility by limiting the functions of USB connection. Set to [Multi] in normal conditions and to [Single] only when the connection cannot be established.	Help Guide
<b>USB Power Supply</b>	Sets whether to supply power via USB connection when the camera is connected to a computer or USB device using a micro USB cable.	187
<b>PC Remote Settings</b>	Controls the PC remote shooting settings.	187
 <b>Language</b>	Selects the language.	46
<b>Date/Time Setup</b>	Sets the date, time, and daylight savings.	46
<b>Area Setting</b>	Sets the location of use.	Help Guide
<b>Copyright Info</b>	Sets copyright information for still images.	Help Guide
<b>Format</b>	Formats the memory card.	178
<b>File Number</b>	Sets the method used to assign file numbers.	179
<b>Set File Name</b>	Changes the first 3 characters of the file names for still images.	179

<b>Select Rec. Media</b>	Selects the memory card slot of the memory card on which to record.	41, Help Guide
<b>Recording Mode</b>	Sets the method for recording images to two memory card slots.	180
<b>Select REC Folder</b>	Changes the folder selected for storing still images and movies (MP4).	181
<b>New Folder</b>	Creates a new folder for storing still images and movies (MP4).	Help Guide
<b>Folder Name</b>	Sets the folder format for still images.	Help Guide
<b>Recover Image DB</b>	Recovers the image database file and enables recording and playback.	Help Guide
<b>Display Media Info.</b>	Displays the remaining recording time of movies and the recordable number of still images on the memory card.	Help Guide
<b>Version</b>	Displays the camera software version.	Help Guide
<b>Certification Logo<sup>2</sup></b>	Displays certification information for the camera (only some of the certification logos are displayed).	Help Guide
<b>Setting Reset</b>	Restores settings to their defaults. Select [Initialize] to restore all settings to their default values.	189

<b>Add Item</b>	Adds desired MENU items to ★ (My Menu).	172
<b>Sort Item</b>	Sorts the MENU items added to ★ (My Menu).	172
<b>Delete Item</b>	Deletes MENU items added to ★ (My Menu).	173
<b>Delete Page</b>	Deletes all the MENU items on a page in ★ (My Menu).	173
<b>Delete All</b>	Deletes all the MENU items added to ★ (My Menu).	173

\*1 If you change this item, you will need to format the memory card for compatibility with the PAL or NTSC system. Also, note that it may not be possible to play back movies recorded for the NTSC system on PAL system TVs.

\*2 Overseas models only.



# List of icons on the monitor

The displayed contents and their positions in the illustrations are just guidelines, and may differ from the actual displays.

## Monitor mode

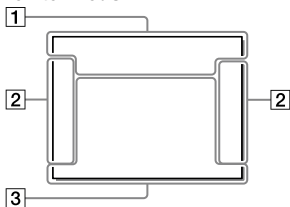

## For playback

### Basic information display



## Viewfinder mode

### [Intelligent Auto] mode

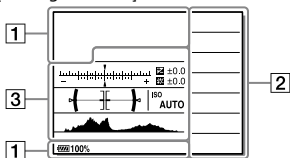

### Histogram display

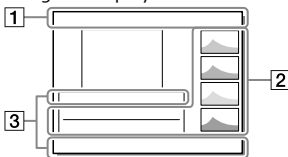



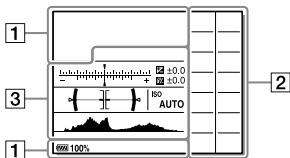









## P/A/S/M mode









1

Display	Indication
	Shooting mode (96)
	Register number (167)
	Scene Recognition icons (97)
	Memory card status (41, 246)
100	Remaining number of recordable images (247)
	Aspect ratio of still images (93)
24M 20M 10M 8.7M 6.0M 5.1M 2.6M 2.2M	Image size of still images (92)
RAW RAW+J RAW RAW+J X.FINE FINE STD	Image quality of still images (93)
120p 60p 60i 30p 24p 100p 50p 50i 25p	Frame rate of movies (143)

Display	Indication
	Record setting of movies (143)
	Bluetooth connection available / Bluetooth connection unavailable (198)
	Connected to smartphone / Not connected to smartphone
	Remaining battery (39)
	Remaining battery warning
	USB power supply (187)
	Flash charge in progress (132)
	APS-C/Super 35mm (95)
	Setting Effect OFF (213)
	AF Illuminator (66)
	NFC active (190)
	Airplane Mode (215)
	No audio recording of movies (149)
	Wind Noise Reduct. (212)
	SteadyShot off/on, Camera shake warning (127)

Display	Indication
	SteadyS. Focal Len./ Camera shake warning (127)
	Obtaining location information/ Location information cannot be obtained (196)
	Overheating warning (236)
	Database file full (236)/Database file error (236)
	Smart Zoom / Clear Image Zoom / Digital Zoom (117)
    	View Mode (158)
<b>100-0003</b>	Folder number – File number (179)
	Protect (161)
<b>XAVCS 4K</b> <b>XAVCS HD</b> <b>AVCHD MP4</b>	File format of movies (142)
<b>DPOF</b>	DPOF set (216)
	Dual Video REC (211)
<b>—PC—</b>	PC remote (187)

Display	Indication
	Shooting without shutter sound (76)
	Bright Monitoring
	Copyright information writing on (218)
<b>120fps 60fps</b> <b>30fps 15fps</b> <b>8fps 4fps</b> <b>100fps 50fps</b> <b>25fps 12fps</b> <b>6fps 3fps 2fps</b> <b>1fps</b>	Frame rate for slow/quick motion shooting (147)
	Writing data / Number of images left to write (153)
	Focus Cancel (90)
	Lock-on AF Cancel (90)
<b>Spot Focus</b>	Performing Spot Focus (91)
	Infrared remote control (182)



Display	Indication
<b>STBY</b>	Movie recording standby
<b>REC 1:00:12</b>	Actual movie recording time (hours: minutes: seconds)
	Focus indicator (52)
<b>1/250</b>	Shutter speed
<b>F3.5</b>	Aperture value
<b>ISO400</b> <b>ISO AUTO</b>	ISO sensitivity (115)
	Exposure Setting Guide (213)
	AE lock (110)/ FEL lock (135)
	Shutter speed indicator (37)
	Aperture indicator (37)
	Histogram (36)
	Location information (196)
<b>90°44'55"N</b> <b>233°44'55"W</b>	Latitude/longitude information (196)
	Digital level gauge (38)
	Audio Level Display (212)
<b>D-R OFF</b> <b>DRO HDR</b> <b>HDR !</b>	DRO (112)/ Auto HDR/Auto HDR image warning (113)
	Picture Effect error

Display	Indication
<b>2017 - 1 - 1</b> <b>10:37AM</b>	Date of recording (46)
<b>3/7</b>	File number/Number of images in the view mode
	REC Control (185)
	STBY
	Spot metering area (108)
<b>00:00:00:00</b>	Time code (hours: minutes: seconds: frames) (218)
<b>00 00 00 00</b>	User Bit (218)

## Troubleshooting

If you experience trouble with the product, try the following solutions.

- 1 Refer to the items on pages 227–233 and check the camera.
- 2 Remove the battery pack, wait for about one minute, re-insert the battery pack, then turn on the power.
- 3 Refer to the “Help Guide” (page 2).
- 4 Initialize the settings (page 189).
- 5 Consult your dealer or local authorized service facility. Additional information on this product and answers to frequently asked questions can be found at our Customer Support Website.  
<http://www.sony.net/>

## Battery pack and power

**The remaining battery level indicator shows an incorrect level, or the power turns off suddenly even though the remaining battery level indicator shows sufficient. You cannot turn on the product.**

- This phenomenon occurs when you use the product in an extremely hot or cold location.
- The battery is depleted. Insert a charged battery.
- The battery life is running out. Replace the battery with a new one.
- Make sure that the battery pack is inserted correctly (page 40).
- Make sure to use a genuine Sony battery pack.

---

**The power turns off suddenly.**

- Depending on the product and battery pack temperature, the product may turn off automatically to protect itself. In this case, a message is displayed on the product screen before the product turns off.

---

**The battery pack discharges quickly.**

- When [Remote Ctrl] has been set to [On], the power save mode will not function. Set [Remote Ctrl] to [Off] after using with a remote control (page 182).

---

**You cannot charge the battery.**

- Turn off the product before charging the battery.

---

**The charge lamp flashes when charging the battery pack.**

- Only NP-FZ100 can be used on the product. Make sure that the battery is NP-FZ100.
- Remove the battery pack and then reattach it (page 41).
- Batteries which have not been used for more than a year may have deteriorated.
- Charging has paused temporarily because the camera is not within the appropriate temperature range. The optimum temperature for charging the battery pack is between 10 °C and 30 °C (50 °F and 86 °F).

## Shooting still images/movies

### No images appear on the viewfinder.

- [FINDER/MONITOR] has been set to [Monitor (Manual)]. Change [FINDER/MONITOR] to [Auto] or [Viewfinder (Manual)] (page 176).
  - Bring your eye close to the viewfinder.
  - When the monitor is pulled out, the eye sensor of the camera will not detect you are approaching even if [FINDER/MONITOR] is set to [Auto]. The image will continue to be displayed on the monitor.
- 

### The shutter cannot be released.

- You are using a memory card with a write-protect switch or an accidental erasure prevention switch, and the switch is set to the LOCK position. Set the switch to the record position.
  - Check the free capacity of the memory card.
  - The lens is not attached properly. Attach the lens properly (page 43).
  - When attaching the product to an astronomical telescope, etc., set [Release w/o Lens] to [Enable] (page 212).
  - Set [Release w/o Card] to [Enable] (page 212). However, when no memory card has been inserted, the images shot will not be saved.
  - The self-timer has been activated.
- 

### Recording takes a long time.

- The noise reduction function is processing an image. This is not a malfunction.
  - You are shooting in RAW mode. Since RAW data files are large, RAW mode shooting may take time.
  - The [Auto HDR] function is processing an image.
- 

### The same image is captured multiple times.

- The drive mode has been set to continuous shooting or bracket shooting. Set the drive mode to [Single Shooting] (page 79).



---

**The image is out of focus.**

- The subject is too close. Check the minimum focal distance of the lens.
- [Focus Mode] has been set to [Manual Focus]. Set [Focus Mode] to a setting other than [Manual Focus] (page 51).
- Ambient light is insufficient.

---

**The image is whitish (Flare).****Blurring of light appears on the image (Ghosting).**

- When pointing the lens toward the strong light source, excessive light enters the lens and the image may come out white (flare) or extraneous light (ghost images) may appear on the image, but this is not a malfunction.

When using the zoom lens, attach the lens hood. Set up the composition so that you shoot images while avoiding backlit condition.

---

**The corners of the picture are too dark.**

- If any filter or hood is used, take it off and try shooting again. Depending on the thickness of the filter and improper attachment of the hood, the filter or the hood may partially appear in the image. The optical properties of some lenses may cause the periphery of the image to appear too dark (insufficient light). You may compensate for this phenomenon with [Shading Comp.] (page 206).

---

**The eyes of the subject come out red.**

- Set [Red Eye Reduction] to [On] (page 209).
- Shoot the subject at a distance closer than the flash range using the flash.

---

### **The image is blurred.**

- The picture was taken in a dark location without the flash, resulting in camera shake. Camera shake is more likely to occur when shooting in a dark location because the shutter speed is slower. The use of a tripod or the flash is recommended (page 132).
- Make sure that [SteadyShot] is set to [On] (page 127).
- If you are using [SteadyShot Adjust.] set to [Manual], check if the right focal-length is set (page 127).

---

### **Sound is not recorded properly.**

- If you turn down the [Audio Rec Level] to the lowest sound level, audio will not be recorded.
- If you turn up the [Audio Rec Level] to the highest sound level, there will likely be sound clipping.

---

### **The camera vibrates while the power is on.**

- The image sensor moves up/down/left/right due to an in-camera anti-blur mechanism. This is not a malfunction.

---

### **Vibration or sounds occur when you shake the camera while the power is turned off.**

- The image sensor vibrates or makes sounds due to an in-camera image sensor shift mechanism. This is not a malfunction.

## **Viewing images**

### **Images cannot be played back.**

- The folder/file name has been changed on your computer.
- When an image file has been processed by a computer or when the image file was recorded using a model other than this product, playback on this product is not guaranteed.
- Copy images stored on the computer using PlayMemories Home to play back the images on the camera.
- The product is in USB mode. Disconnect the product from the computer (page 202).

## Deleting images

### The image cannot be deleted.

- Cancel the protection.

---

### The image was deleted by mistake.

- Once you have deleted an image, you cannot restore it. We recommend that you protect images that you do not want to delete (page 161).

## Computers

### You do not know which operating systems are compatible.

- You can confirm the operating computer environment of the software from the following URL:  
<http://www.sony.net/pcenv/>

---

### The computer does not recognize this product.

- Check that the power of the camera is turned on.
- If the battery level is low, insert a charged battery pack.
- Use the micro USB cable (supplied) to connect the devices.
- Disconnect the USB cable, and connect it again firmly.
- Disconnect all equipment other than this product, the keyboard and the mouse from the USB terminals of your computer.
- Connect this product directly to your computer without passing through a USB hub or other device.

---

### You cannot copy images.

- Connect this product and your computer correctly making a USB connection (page 201).
- Copy images using a procedure supported by your operating system.
- When you shoot images with a memory card formatted by a computer, you may not be able to copy the images to a computer. Shoot using a memory card formatted by this product (page 178).

---

### **Images cannot be played back.**

- If you are using PlayMemories Home, refer to the Help of PlayMemories Home.
- Consult the computer manufacturer or software manufacturer.

---

### **PlayMemories Home does not launch automatically when you connect the product to your computer via USB.**

- Establish the USB connection when the computer is turned on.

## **Printing**

### **You cannot print images.**

- RAW images cannot be printed. To print RAW images, first convert them to JPEG images using Image Data Converter.

---

### **The color of the image is strange.**

- When you print the images recorded in Adobe RGB mode using sRGB printers that are not compatible with Adobe RGB, the images are printed at a lower saturation (page 126).

---

### **Images are printed with both edges cut off.**

- Depending on your printer, the left, right, top, and bottom edges of the image may be cut off. Especially when you print an image shot with [Aspect Ratio] set to [16:9], the lateral end of the image may be cut off.
- When printing images using your printer, cancel the trimming or borderless settings of the printer. Consult the printer manufacturer as to whether the printer provides these functions or not.
- When you print images at a shop, ask the shop whether they can print the images without cutting off both edges.

## Others

**The message [Set Area/Date/Time.] is displayed when you turn on the product.**

- The date and time settings were lost because the battery was left in the depleted state or removed from the product. Charge the battery and reset the date and time (page 46). If the clock resets every time the battery pack is charged, the internal rechargeable backup battery may be worn out. Consult your service facility.

---

**The number of recordable images does not decrease, or decreases two images at a time.**

- This is because the compression rate and the image size after compression change depending on the image when you shoot a JPEG image.

---

**Settings are reset even though the resetting operation has not been performed.**

- The camera settings may be reset if the battery pack is ejected while the ON/OFF (Power) switch is set to "ON." When ejecting the battery pack, first set the ON/OFF (Power) switch to "OFF" and make sure that the access lamp is not illuminated before ejecting (page 25, 41).

---

**The product does not work properly.**

- Turn off the product. Remove the battery pack and insert it again. If the product is hot, remove the battery pack, and allow it to cool down before trying this corrective procedure.
- If an AC Adaptor is used, disconnect the power cord. Connect the power cord and turn on the product again. If the product repeats the same error often or still does not work after trying these solutions, consult your Sony dealer or local authorized Sony service facility.

---

**"--E-" appears on the screen.**

- Remove the memory card, and insert it again (page 43). If the problem persists even after performing this procedure, format the memory card (page 178).

# Warning messages

---

## **Set Area/Date/Time.**

- Set the area, date and time. If you have not used the product for a long time, charge the internal rechargeable backup battery.
- 

## **Power insufficient.**

- The image copying or image sensor cleaning functions will not operate because the remaining battery level is too low. Recharge the battery pack.
- 

## **Unable to use memory card. Format?**

- The memory card was formatted on a computer and the file format was modified. Select [Enter] and then format the memory card. You can use the memory card again, however, all previous data in the memory card is erased. It may take some time to complete the format. If the message still appears, change the memory card.
- 

## **Memory Card Error**

- An incompatible memory card is inserted.
  - Formatting has failed. Format the memory card again (page 178).
- 

## **Unable to read memory card. Reinsert memory card.**

- An incompatible memory card is inserted.
  - The memory card is damaged.
  - The terminal section of the memory card is dirty.
- 

## **Memory card locked.**

- You are using a memory card with a write-protect switch or a delete-protect switch with the switch set to the LOCK position. Set the switch to the record position.

---

**Cannot open the shutter since the memory card is not inserted.**

- No memory card has been inserted into the memory card slot selected in [Select Rec. Media].
- To release the shutter without inserting a memory card into the camera, set [Release w/o Card] to [Enable] (page 212). In this case, images will not be saved.

---

**This memory card may not be capable of recording and playing normally.**

- An incompatible memory card is inserted.

---

**Processing...**

- When performing noise reduction, the reduction process takes place. You cannot do any further shooting during this reduction process.

---

**Unable to display.**

- Images recorded with other products or images modified with a computer may not be displayed.
- Processing on the computer such as deletion of the image files may cause inconsistencies in the image database files. Repair the image database files (page 219).

---

**Check that a lens is mounted.****For an unsupported lens, set "Release w/o Lens" in the menu to "Enable".**

- The lens is not attached properly, or the lens is not attached. If the message appears when a lens is attached, reattach the lens (page 45). If the message appears frequently, check whether the contacts of the lens and product are clean or not.
- When attaching the product to an astronomical telescope or similar instrument, or using an unsupported lens, set [Release w/o Lens] to [Enable] (page 212).

---

**Unable to print.**

- You tried to mark RAW images with a DPOF mark.

---

**Internal temp. high. Allow it to cool.**

- The product has become hot because you have been shooting continuously.  
Turn the power off and cool the product and wait until the product is ready to shoot again.



- You have been recording images for a long time, the product temperature has risen.

---

**Recording is unavailable in this movie format.**

- Set [File Format] to [MP4] (page 142).



- The number of images exceeds that for which date management in a database file by the product is possible.



- Unable to register to the database file. Import all the images to a computer using PlayMemories Home and recover the memory card.

---

**Image DataBase File error**

- There is something wrong in the Image Database File. Select [Setup] → [Recover Image DB] (page 219).

---

**System Error****Camera Error. Turn power off then on.**

- Remove the battery pack, and then re-insert it. If the message appears frequently, consult local authorized Sony service facility.

---

**Image Database File error. Recover?**

- You cannot record and play back an AVCHD movie because the Image Database File is damaged. Recover the Image Database File following the on-screen instructions.



---

**Unable to magnify.**

**Unable to rotate image.**

- Images recorded with other products may not be enlarged or rotated.

---

**Cannot create more folders.**

- A folder in the memory card has the first three digits "999." You cannot create any more folders on this camera.

## Cleaning the image sensor

If dust or debris gets inside the camera and adheres to the surface of the image sensor (the part that converts the light to an electric signal), it may appear as dark spots on the image, depending on the shooting environment. If this happens, follow the steps below to clean the image sensor.

---

**1 Confirm that the battery has been charged sufficiently.**

---

**2 MENU** →  (Setup) → [Cleaning Mode] → [Enter].

The image sensor vibrates a little to shake off the dust.

---

**3 Turn off the product following the instructions on the screen.**

---

**4 Detach the lens.**

---

**5 Use the blower to clean the image sensor surface and the surrounding area.**

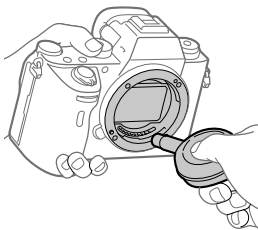

---

**6 Attach the lens.**

---

### Hint

- For how to check the amount of dust on the image sensor, and for further details on cleaning methods, please refer to the following URL.  
<http://support.d-imaging.sony.co.jp/www/support/ilc/sensor/index.php>

### Note

- Clean the image sensor quickly.
- A blower is not supplied with this product. Use a commercially available blower.
- Make sure that the remaining battery level is  (3 remaining battery icons) or more before performing the cleaning. The use of an AC Adaptor (supplied) is recommended.
- Do not use a spray type blower as it may scatter water droplets inside the camera body.
- Do not put the tip of a blower into the cavity beyond the lens mount area, so that the tip of the blower does not touch the image sensor.
- Hold the camera slightly face downward so that the dust falls out.
- Do not subject the product to any shock during cleaning.
- When cleaning the image sensor with a blower, do not blow too hard. If you blow the sensor too hard, the inside of the product may be damaged.
- If the dust remains even after you cleaned the product as described, consult the service facility.

# Mount Adaptor

Using a Mount Adaptor (sold separately), you can attach an A-mount lens (sold separately) to this product.

For details, refer to the operating instructions supplied with the Mount Adaptor.

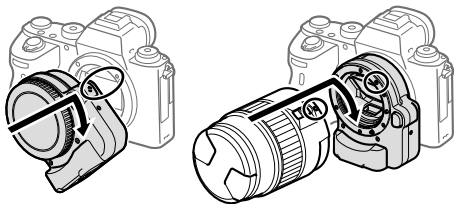

## Note

- You may not be able to use the Mount Adaptor or auto-focus with certain lenses. Consult your Sony dealer or local authorized Sony service facility on compatible lenses.
- The LA-EA2 or LA-EA4 Mount Adaptor (both sold separately) and the vertical grip (sold separately) are not designed to be attached at the same time. If you attach them at the same time, the space between the Mount Adaptor and the vertical grip will become narrow, making the camera difficult to hold.
- You cannot use the AF illuminator when using an A-mount lens.
- The sound of the lens and the product in operation may be recorded during movie recording. You can turn the sound off by selecting MENU →  2 (Camera Settings 2) → [Audio Recording] → [Off].
- It may take a long time or may be difficult for the product to focus, depending on the lens used or the subject.

## LA-EA1/LA-EA3 Mount Adaptor

If you use the LA-EA1 Mount Adaptor (sold separately) or LA-EA3 Mount Adaptor (sold separately), the following functions are available.

### Full frame shooting:

LA-EA1: Not available

LA-EA3: Available with full frame shooting-compatible lenses only

**Autofocus:** Available with SAM/SSM lens only

**AF system:** Phase Detection AF/Contrast AF

**AF/MF select:** Can be changed using the operating switch on the lens.

**Focus Mode:** Single-shot AF/Continuous AF\*

\* This setting is unavailable when [AF System] is set to [Contrast AF].

- When using a Mount Adaptor and the camera is set to movie mode, the Auto Focus only works when the shutter button is pressed halfway down or when using the [AF On] function.
- When using a Mount Adaptor in movie mode, adjust the aperture manually.

### Available focus area:

When [AF System] is set to [Phase Detection AF]:

[Wide]/[Center]/[Flexible Spot]

When [AF System] is set to [Contrast AF]:

[Wide]/[Zone]/[Center]/[Flexible Spot]/[Expand Flexible Spot]

**SteadyShot:** In-body

## LA-EA2/LA-EA4 Mount Adaptor

If you use the LA-EA2 Mount Adaptor (sold separately) or LA-EA4 Mount Adaptor (sold separately), the following functions are available.

### **Full frame shooting:**

LA-EA2: Not available

LA-EA4: Available with full frame shooting-compatible lenses only

### **Autofocus:** Available

**AF system:** Phase Detection AF, which is controlled by the dedicated AF sensor inside the Mount Adaptor

### **AF/MF select:**

Lenses that do not support DMF (with the focus mode switch): Can be changed using the focus mode switch on the lens.

Lenses that support DMF (with the focus mode switch): Can be changed using the focus mode switch on the lens. When the focus mode switch on the lens is set to AF, you can change the focusing method by the operation of the camera.

Other lenses (without the focus mode switch): Can be changed by the operation of the camera.

### **Focus Mode:**

Single-shot AF/Continuous AF/DMF\*

\* Only available when using lenses that support Direct Manual Focus.

- Even if [Priority Set in AF-S] is set to [Balanced Emphasis], it will temporarily be switched to [AF].
- Even if [Priority Set in AF-C] is set to [Balanced Emphasis], it will temporarily be switched to [Release].

### **Available focus area:**

Wide/Center/Flexible Spot/Lock-on AF

### **SteadyShot:** In-body

## Continuous shooting using a Mount Adaptor

When a Mount Adaptor is attached to the camera, the auto-focusing method during continuous shooting varies depending on the settings for [Cont. Shooting] and [Shutter Type].

**When using the LA-EA1 Mount Adaptor (sold separately), LA-EA2 Mount Adaptor (sold separately) or LA-EA4 Mount Adaptor (sold separately)**

	Shutter Type	
	Mechanical Shut.	Auto/Electronic Shut.
<b>Continuous Shooting: Hi</b>	The focus is locked to the setting in the first shot.	
<b>Continuous Shooting: Mid</b>		
<b>Continuous Shooting: Lo</b>	The focus continuously tracks the subjects.	

## When using the LA-EA3 Mount Adaptor (sold separately)

Update the firmware of the Mount Adaptor to the latest version in advance.

	Shutter Type	
	Mechanical Shut.	Auto/Electronic Shut.
<b>Continuous Shooting: Hi</b>	The focus continuously tracks the subjects.*1	The focus continuously tracks the subjects.*1*2
<b>Continuous Shooting: Mid</b>	The focus continuously tracks the subjects.*1	
<b>Continuous Shooting: Lo</b>	The focus continuously tracks the subjects.	

\*1 When the F-value is greater than F11, the focus does not track the subjects. The focus is locked to the setting in the first shot.

\*2 The continuous shooting speed varies depending on the [Focus Mode] setting.

– [Single-shot AF]/[DMF]/[Manual Focus]: Maximum of 20 images per second (the focus is locked to the setting in the first shot).

– [Continuous AF]: Maximum of 10 images per second

### Note

- When you are using a Mount Adaptor, you cannot perform blackout-free continuous shooting in [Continuous Shooting: Lo] mode (page 76).

# Vertical grip



You can attach a vertical grip (sold separately) to this product and record vertically oriented images. When attaching the vertical grip, remove the battery cover in advance. For details, refer to the operating instructions for the vertical grip.

## How to remove the battery cover

Slide the battery cover release lever of this product in the direction of the arrow.

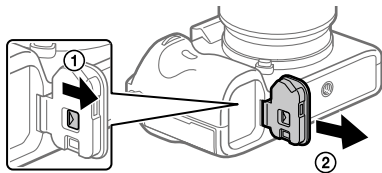
The shaft of the battery cover will be stored inside the battery cover.



- You can attach the removed battery cover to the vertical grip so that you do not lose it.
- When a vertical grip is attached to this product, the battery remaining is displayed as 1  2 .

## How to attach the battery cover

Slide the battery cover release lever and align the battery cover hinge with the battery cover shaft hole to attach the battery cover.

### Hint

- The battery pack inside the vertical grip can be charged while the vertical grip is attached to the camera.  
Turn off the camera and connect the camera to the AC Adaptor (supplied) using the micro USB cable (supplied), then connect the AC Adaptor to the wall outlet (wall socket).

### Note

- The LA-EA2/LA-EA4 Mount Adaptor (sold separately) and the vertical grip are not designed to be attached at the same time. If you attach them at the same time, the space between the Mount Adaptor and the vertical grip will become narrow, making the camera difficult to hold.



# Specifications

## Battery life and number of recordable images

		Battery life	Number of images
Shooting (still images)	Screen mode	—	Approx. 650
	Viewfinder mode	—	Approx. 480
Actual shooting (movies)	Screen mode	Approx. 120 min.	—
	Viewfinder mode	Approx. 105 min.	—
Continuous shooting (movies)	Screen mode	Approx. 195 min.	—
	Viewfinder mode	Approx. 185 min.	—

- The above estimates for battery life and number of recordable images apply when the battery pack has been fully charged. The battery life and number of images may decrease depending on the conditions of use.
- The battery life and number of recordable images are estimates based on shooting with the default settings under the following conditions:
  - Using the battery pack at an ambient temperature of 25°C (77°F).
  - Using a Sony SDXC memory card of UHS-I Speed Class 3 (**3**) (sold separately)
  - Using a lens FE 28-70 mm F3.5-5.6 OSS (sold separately)
- The numbers for “Shooting (still images)” are based on the CIPA standard and shooting under the following conditions: (CIPA: Camera & Imaging Products Association)
  - One picture is taken every 30 seconds.
  - The power is turned on and off once every ten times.
- The number of minutes for movie shooting is based on the CIPA standard and shooting under the following conditions:
  - The image quality is set to XAVC S HD 60p 50M / 50p 50M.
  - Actual shooting (movies): Battery life based on repeatedly shooting, zooming, shooting stand-by, turning on/off, etc.
  - Continuous shooting (movies): Battery life based on non-stop shooting until the limit (29 minutes) has been reached, and then continued by pressing the MOVIE (Movie) button again. Other functions, such as zooming, are not operated.

## Memory cards that can be used

You can use the following types of memory cards with this camera. The ✓ mark indicates that these memory cards can be used for shooting still images or movies.

When using Memory Stick Micro media or microSD memory cards with this camera, make sure to use with the appropriate adaptor.

Memory card	For still images	For movies		
		MP4	AVCHD	XAVC S
Memory Stick PRO Duo	✓	✓ (Mark2 only)	✓ (Mark2 only)	—
Memory Stick PRO-HG Duo	✓	✓	✓	✓*1
Memory Stick Micro (M2)	✓	✓ (Mark2 only)	✓ (Mark2 only)	—
SD memory card	✓	✓*2	✓*2	—
SDHC memory card	✓	✓*3	✓*3	✓*4
SDXC memory card	✓	✓*3	✓*3	✓*4
microSD memory card	✓	✓*2	✓*2	—
microSDHC memory card	✓	✓*3	✓*3	✓*4
microSDXC memory card	✓	✓*3	✓*3	✓*4

\*1 Movies cannot be recorded in 100 Mbps or more.

\*2 Memory card compatible with SD Speed Class 4 (CLASS 4) or faster

\*3 Memory card compatible with SD Speed Class 4 (CLASS 4) or faster, or with UHS-I or UHS-II

\*4 Memory card compatible with SD Speed Class 10 (CLASS 10), or with UHS-I or UHS-II

When recording at 100 Mbps or more, a UHS-I U3 or UHS-II U3 memory card is required.

## Note

- Use the slot 1 when you are using a UHS-II memory card. Also, set [Select Rec. Media] to [Slot 1].
- Memory Stick PRO Duo media cannot be used in the slot 1.
- When an SDHC memory card is used to record an XAVC S movie over extended periods of time, the recorded movies will be divided into files 4 GB in size. The divided files can be handled as a single file by importing them to a computer using PlayMemories Home.
- When recording a movie on memory cards in both the slot 1 and the slot 2 with following camera settings, insert two memory cards with the same file system. XAVC S movies cannot be recorded simultaneously when using a combination of the exFAT file system and FAT32 file system.
  - [File Format] is set to [XAVC S 4K] or [XAVC S HD]
  - [Recording Mode] is set to [Simult. (📷📷)] or [Simult. (📷📷)]

Memory card	File system
SDXC memory card	exFAT
Memory Stick PRO Duo (Mark2) Memory Stick PRO-HG Duo SDHC memory card	FAT32

## Number of recordable images

When you insert a memory card into the camera and set the ON/OFF (Power) switch to “ON,” the number of images that can be recorded (should you continue to shoot using the current settings) is displayed on the screen.

## Note

- When “0” (the number of recordable images) flashes in orange, the memory card is full. Replace the memory card with another one, or delete images from the current memory card.
- When “NO CARD” flashes in orange, it means no memory card has been inserted. Insert a memory card.

## ■ The number of images that can be recorded on a memory card

The table below shows the approximate number of images that can be recorded on a memory card formatted with this camera. The values are defined using Sony standard memory cards for testing. The values may vary depending on the shooting conditions and the type of memory card used.

[ Image Size]: [L: 24M]

[ Aspect Ratio]: [3:2]\*

(Units: Images)

Quality	8 GB	16 GB	32 GB	64 GB
Standard	1100	2300	4600	9200
Fine	790	1600	3200	6400
Extra fine	435	870	1750	3500
RAW & JPEG (Compressed RAW)	215	435	870	1750
RAW (Compressed RAW)	295	600	1200	2400
RAW & JPEG (Uncompressed RAW)	125	255	510	1000
RAW (Uncompressed RAW)	150	305	610	1200

\* When [ Aspect Ratio] is set to other than [3:2], you can record more images than the numbers shown in the table above (except when [RAW] is selected).

### Note

- Even if the number of recordable images is higher than 9999 images, “9999” will appear.
- When an image shot with another product is played back on this camera, the image may not appear in its actual size.
- The numbers shown are when using a Sony memory card.

## Recordable movie times

The table below shows the approximate total recording times using a memory card formatted with this camera. The values may vary depending on the shooting conditions and the type of memory card used. The recording times for when [File Format] is set to [XAVC S 4K], [XAVC S HD], and [AVCHD] are recording times when shooting with [Dual Video REC] set to [Off].

(h (hour), m (minute))

File Format	Record Setting	8 GB	16 GB	32 GB	64 GB
XAVC S 4K	30p 100M/ 25p 100M	9 m	15 m	35 m	1 h 15 m
	30p 60M/ 25p 60M	15 m	30 m	1 h	2 h 5 m
	24p 100M*	9 m	15 m	35 m	1 h 15 m
	24p 60M*	15 m	30 m	1 h	2 h 5 m
XAVC S HD	120p 100M/ 100p 100M	9 m	15 m	35 m	1 h 15 m
	120p 60M/ 100p 60M	15 m	30 m	1 h	2 h 5 m
	60p 50M/ 50p 50M	15 m	35 m	1 h 15 m	2 h 35 m
	30p 50M/ 25p 50M	15 m	35 m	1 h 15 m	2 h 35 m
	24p 50M*	15 m	35 m	1 h 15 m	2 h 35 m
AVCHD	60i 24M (FX)/ 50i 24M (FX)	40 m	1 h 25 m	3 h	6 h
	60i 17M (FH)/ 50i 17M (FH)	55 m	2 h	4 h 5 m	8 h 15 m
	60p 28M (PS)/ 50p 28M (PS)	35 m	1 h 15 m	2 h 30 m	5 h 5 m
	24p 24M (FX)/ 25p 24M (FX)	40 m	1 h 25 m	3 h	6 h
	24p 17M (FH)/ 25p 17M (FH)	55 m	2 h	4 h 5 m	8 h 15 m

File Format	Record Setting	8 GB	16 GB	32 GB	64 GB
MP4	1920×1080 60p 28M/50p 28M	35 m	1 h 15 m	2 h 35 m	5 h 20 m
	1920×1080 30p 16M/25p 16M	1 h	2 h	4 h 10 m	8 h 25 m
	1280×720 30p 6M/25p 6M	2 h 35 m	5 h 20 m	10 h 55 m	22 h

- \* Only when [NTSC/PAL Selector] is set to NTSC
- Continuous shooting is possible for approximately 29 minutes (a product specification limit). The continuous recordable time may differ in the following situations:
    - When the file format is set to MP4 (28M): Approximately 20 minutes (limited by file size of 4 GB).
    - When shooting slow-motion/quick-motion movies: Recording will automatically stop when the recorded file reaches approximately 29 minutes (the played back movie reaches approximately 29 minutes).  
(Recording will automatically stop when the recorded file reaches approximately 15 minutes if [S&Q Record Setting] is set to [60p/50p] and [S&Q Frame Rate] is set to [30fps/25fps].)
  - The times for slow-motion/quick-motion movies are playback times, not recording times.

#### Note

- The recordable time of movies varies because the camera is equipped with VBR (Variable Bit-Rate), which automatically adjusts image quality depending on the shooting scene. When you record a fast-moving subject, the image is clearer but the recordable time is shorter because more memory is required for recording. The recordable time also varies depending on the shooting conditions, the subject or the image quality/size settings.
- The times shown are recordable times using a Sony memory card.

## Notes on continuous movie recording

- High-quality movie recording and high-speed continuous shooting require large amounts of power. Therefore, if you continue to shoot, the temperature inside the camera will rise, especially that of the image sensor. In such cases, the camera will turn off automatically because the surface of the camera is heated to a high temperature or the high temperature affects the quality of the images or the internal mechanism of the camera.
- The duration of time available for continuous movie recording when the camera records with the default settings after the power has been turned off for a while is as follows. The values indicate the continuous time from when the camera starts recording until the camera stops recording.

Ambient temperature	Continuous recording time for movies (HD)	Continuous recording time for movies (4K)
20°C (68°F)	Approx. 29 min.	Approx. 29 min.
30°C (86°F)	Approx. 29 min.	Approx. 29 min.
40°C (104°F)	Approx. 29 min.	Approx. 29 min.

[Auto Pwr OFF Temp.]: [Standard]

HD: XAVC S HD (60p 50M/50p 50M, not connected via Wi-Fi)

4K: XAVC S 4K (24p 60M/25p 60M, not connected via Wi-Fi)

- The duration of time available for movie recording varies with the temperature, file format/record setting for movies, Wi-Fi network environment, or condition of the camera before you start recording. If you frequently recompose or shoot images after the power is turned on, the temperature inside the camera will rise and the recording time available will be shorter.
- When [H] is indicated, the temperature of the camera is too high.
- If the camera stops movie recording due to a high temperature, leave it for some time with the power turned off. Start recording after the temperature inside the camera drops fully.
- If you observe the following points, you will be able to record movies for longer periods of time.
  - Keep the camera out of direct sunlight.
  - Turn the camera off when it is not being used.
- When [File Format] is set to [AVCHD], the file size of movies is limited to approx. 2 GB. If the movie file size reaches approx. 2 GB during recording, a new movie file will be created automatically.
- When [File Format] is set to [MP4], the file size of movies is limited to approx. 4 GB. If the movie file size reaches approx. 4 GB during recording, recording will stop automatically.

## Specifications

### Camera

#### [System]

##### Camera Type

Interchangeable Lens Digital Camera

##### Lens

Sony E-mount lens

#### [Image sensor]

##### Image format

35 mm full frame (35.6 mm × 23.8 mm), CMOS image sensor

##### Effective pixel number of camera

Approx. 24 200 000 pixels

##### Total pixel number of camera

Approx. 28 300 000 pixels

#### [SteadyShot]

##### System

In-camera sensor shift image stabilization system

#### [Anti-Dust]

##### System

Charge protection coating on optical filter and image sensor shift mechanism

#### [Auto focus system]

##### Detection system

Phase detection system/Contrast detection system

##### Sensitivity Range

-3 EV to +20 EV (at ISO 100 equivalent, F2.0)

##### AF illuminator

Approx. 0.3 m to 3 m (0.99 ft. to 9.8 ft.) (When using an FE 28-70 mm F3.5-5.6 OSS)

#### [Electronic viewfinder]

##### Type

Electronic viewfinder

##### Total number of dots

3 686 400 dots

##### Frame coverage

100%

##### Magnification

Approx. 0.78× with 50 mm lens at infinity, -1 m<sup>-1</sup>

##### Eye Point

Approx. 23 mm from the eyepiece and approx. 18.5 mm from the eyepiece frame at -1 m<sup>-1</sup> (CIPA standard compliant)

##### Diopter Adjustment

-4.0 m<sup>-1</sup> to +3.0 m<sup>-1</sup>

#### [Monitor]

##### LCD monitor

7.5 cm (3.0 type) TFT drive, touch panel

##### Total number of dots

1 440 000 dots

#### [Exposure control]

##### Metering method

1 200-zone evaluative metering

##### Metering Range

-3 EV to +20 EV (at ISO 100 equivalent with F2.0 lens)



**ISO sensitivity (Recommended exposure index)**

Still images: ISO 100 to ISO 51 200 (Extended ISO: Minimum ISO 50, maximum ISO 204 800), [ISO AUTO] (ISO 100 to ISO 6 400, Maximum/Minimum can be set.)

Movies: ISO 100 to ISO 51 200 equivalent (Extended ISO: Minimum ISO 100, maximum ISO 102 400), [ISO AUTO] (ISO 100 to ISO 6 400 equivalent, Maximum/Minimum can be set.)

**Exposure compensation**

±5.0 EV (switchable between 1/3 EV and 1/2 EV steps)

When using exposure compensation dial: ±3.0 EV (1/3 EV step)

**[Shutter]****Type**

Electronically-controlled, vertical-traverse, focal-plane type

**Speed range**

Still images (when shooting with the electronic shutter): 1/32 000 second\* to 30 seconds (up to 1/8 second in continuous shooting)

\* Available only in the M (Manual Exposure) and S (Shutter Priority) modes. For details, refer to the "Help Guide."

Still images (when shooting with the mechanical shutter): 1/8 000 second to 30 seconds, BULB



Movies: 1/8 000 second to 1/4 second (1/3 EV step)

- 1080 60i-compatible devices: up to 1/60 second in AUTO mode (up to 1/30 second in Auto slow shutter mode)
- 1080 50i-compatible devices: up to 1/50 second in AUTO mode (up to 1/25 second in Auto slow shutter mode)

**Flash sync speed**

1/250 second (when using a flash manufactured by Sony)

**[Continuous shooting]****Continuous shooting speed (when shooting with the electronic shutter)**

 Hi: Maximum of approx. 20 images per second/  
 MD: Maximum of approx. 10 images per second/  
 Lo: Maximum of approx. 5 images per second

- Based on our measurement conditions. The speed of continuous shooting can be slower, depending on the shooting conditions.

**[Recording format]****File format**

JPEG (DCF Ver. 2.0, Exif Ver. 2.31, MPF Baseline) compliant, RAW (Sony ARW 2.3 format)

**Movie (XAVC S format)**

MPEG-4 AVC/H.264 XAVC S ver.1.0 format compliant

Video: MPEG-4 AVC/H.264

Audio: LPCM 2ch (48 kHz 16 bit)

**Movie (AVCHD format)**

AVCHD format Ver. 2.0 compatible

Video: MPEG-4 AVC/H.264

Audio: Dolby Digital 2ch, equipped with Dolby Digital Stereo Creator

- Manufactured under license from Dolby Laboratories.

**Movie (MP4 format)**

Video: MPEG-4 AVC/H.264

Audio: MPEG-4 AAC-LC 2ch

**[Recording media]**

Memory Stick media, SD cards

- For details, see "Memory cards that can be used" (page 246).

## [Slot]

### SLOT 1

Slot for SD cards (UHS-I and UHS-II compatible)

### SLOT 2

Multi-slot for Memory Stick PRO Duo media and SD cards (UHS-I compatible)

Supports operations between two memory cards.

## [Input/output terminals]

### Multi/Micro USB Terminal\*

Hi-Speed USB (USB 2.0)

\* Supports Micro USB compatible devices.

### HDMI

HDMI type D micro jack

### (Microphone) terminal

∅ 3.5 mm Stereo mini jack

### (Headphones) terminal

∅ 3.5 mm Stereo mini jack

### LAN terminal

### (Flash sync) terminal

## [Power, general]

### Battery pack

Rechargeable battery pack NP-FZ100

### Power consumption (while shooting)

Using an FE 28-70 mm F3.5-5.6 OSS

When using the viewfinder:

Approx. 4.1 W

When using the monitor:

Approx. 3.0 W

## [Others]

### Microphone

Stereo

### Speaker

Monaural

### Exif Print

Compatible

### DPOF

Compatible

### PRINT Image Matching III

Compatible

### Dimensions

Approx. 126.9 mm × 95.6 mm × 63.0 mm

(Approx. 5 inches × 3 7/8 inches × 2 1/2 inches) (W/H/D, excluding protrusions)

### Mass

Approx. 673 g (1 lb 7.7 oz) (including battery pack and SD card)

Approx. 588 g (1 lb 4.7 oz) (body only)

### Operating temperature

0°C to 40°C (32°F to 104°F)

### Storage temperature

-20°C to +60°C (-4°F to +140°F)

## [Wireless LAN]

### Supported format

IEEE 802.11 b/g/n

### Frequency band

2.4 GHz

### Security

WEP/WPA-PSK/WPA2-PSK

### Connection method

Wi-Fi Protected Setup™ (WPS)/  
Manual

### Access method

Infrastructure mode

## [NFC]

### Tag type

NFC Forum Type 3 Tag compliant

## [Bluetooth communications]

Bluetooth standard Ver. 4.1

### Frequency band

2.4 GHz

Model No. WW361847

## Battery charger BC-QZ1

### Input rating

AC 100 V to 240 V, 50 Hz/60 Hz,  
0.38 A

### Output rating

DC 8.4 V, 1.6 A

## AC Adaptor AC-UUD12/AC-UUE12

### Power requirements

AC 100 V to 240 V, 50 Hz/60 Hz, 0.2 A

### Output voltage

DC 5 V, 1.5 A

## Rechargeable battery pack

### NP-FZ100

#### Nominal voltage



DC 7.2 V

Design and specifications are subject to change without notice.

### On image data compatibility

- This camera conforms with DCF (Design rule for Camera File system) universal standard established by JEITA (Japan Electronics and Information Technology Industries Association).
- Playback of images recorded with your camera on other equipment and playback of images recorded or edited with other equipment on your camera are not guaranteed.

## Trademarks

- Memory Stick and  are trademarks or registered trademarks of Sony Corporation.
- XAVC S and  are registered trademarks of Sony Corporation.
- "AVCHD Progressive" and the "AVCHD Progressive" logotype are trademarks of Panasonic Corporation and Sony Corporation.
- Mac is a trademark of Apple Inc., registered in the United States and other countries.
- IOS is a registered trademark or trademark of Cisco Systems, Inc.
- iPhone and iPad are trademarks of Apple Inc., registered in the U.S. and other countries.
- Blu-ray Disc™ and Blu-ray™ are trademarks of the Blu-ray Disc Association.
- DLNA and DLNA CERTIFIED are trademarks of Digital Living Network Alliance.
- Dolby, Dolby Audio and double-D symbol are trademarks of Dolby Laboratories.
- The terms HDMI and HDMI High-Definition Multimedia Interface, and the HDMI Logo are trademarks or registered trademarks of HDMI Licensing, LLC in the United States and other countries.
- Microsoft and Windows are registered trademarks or trademarks of Microsoft Corporation in the United States and/or other countries.
- SDXC logo is a trademark of SD-3C, LLC.

- Facebook and the “f” logo are trademarks or registered trademarks of Facebook, Inc.
- Android and Google Play are trademarks or registered trademarks of Google Inc.
- YouTube and the YouTube logo are trademarks or registered trademarks of Google Inc.
- Wi-Fi, the Wi-Fi logo and Wi-Fi Protected Setup are registered trademarks or trademarks of the Wi-Fi Alliance.
- The N Mark is a trademark or registered trademark of NFC Forum, Inc. in the United States and in other countries.
- The Bluetooth® word mark and logos are registered trademarks owned by the Bluetooth SIG, Inc. and any use of such marks by Sony Corporation is under license.
- QR code is a trademark of Denso Wave Inc.
- In addition, system and product names used in this manual are, in general, trademarks or registered trademarks of their respective developers or manufacturers. However, the ™ or ® marks may not be used in all cases in this manual.



## ■ On GNU GPL/LGPL applied software

The software that is eligible for the following GNU General Public License (hereinafter referred to as "GPL") or GNU Lesser General Public License (hereinafter referred to as "LGPL") are included in the product.

This informs you that you have a right to have access to, modify, and redistribute source code for these software programs under the conditions of the supplied GPL/LGPL. Source code is provided on the web. Use the following URL to download it. <http://oss.sony.net/Products/Linux/> We would prefer you do not contact us about the contents of source code.

Licenses (in English) are recorded in the internal memory of your product. Establish a Mass Storage connection between the product and a computer to read licenses in the "PMHOME" - "LICENSE" folder.

Additional information on this product and answers to frequently asked questions can be found at our Customer Support Website.

<http://www.sony.net/>

## 0-9

4K Output Sel.....	152
24p/60p Output.....	183

## A

A .....	99
Access Point Set.....	195
Add Item .....	172
AdobeRGB.....	126
AEL .....	110
AEL button .....	137
AE lock.....	110
AEL w/ shutter .....	209
AF .....	53
AF Area Auto Clear.....	208
AF Area Regist.....	63
AF-C.....	51
AF drive speed .....	211
AF Illuminator.....	66
AF in Focus Mag.....	60
AF/MF control .....	58
AF Micro Adj.....	67
AF On.....	59
AF-S.....	51
AF System .....	68
AF Track Sens .....	207, 211
AF w/ shutter .....	208
Airplane Mode .....	215
Angle of view for movies.....	146
Aperture Preview .....	174
Aperture Priority .....	99
APS-C/Super 35mm.....	95
Area Setting .....	218
Aspect .....	151

Aspect Ratio.....	93
Audio Level Display .....	212
Audio Out Timing .....	212
Audio Rec Level .....	150
Audio Recording .....	149
Audio recording of movies .....	149
Audio signals .....	214
Autoflash.....	133
Auto focus.....	53
Auto HDR .....	113
Auto Mode .....	47
Auto Pwr OFF Temp .....	217
Auto Review.....	174
Auto Slow Shut.....	211
Autumn leaves.....	124
AVCHD.....	143
AWB.....	120

## B

Battery pack .....	40
Blackout-free shooting .....	75
Black & White.....	124
Bluetooth Function .....	190, 197
Bluetooth Settings .....	197
Bracket Settings .....	89
"BRAVIA" Sync .....	165
BULB.....	102
Bulb shooting.....	102

## C

Camera Settings 1 .....	206
Camera Settings 2.....	211
Center.....	53, 108, 109, 151
Center Lock-on AF.....	61
Certification Logo.....	219

Charging.....	39	Dial Ev Comp.....	214
Cleaning Mode.....	238	Dial Setup.....	214
Clear.....	123	Digital zoom.....	117, 118
Clear Image Zoom.....	117, 118	Diopter-adjustment.....	25
Clock setting.....	46	Direct manual focus.....	51, 70
Cloudy.....	120	DISP.....	35
Color Space.....	126	DISP Button.....	37
Compatible lenses.....	45	Disp. cont. AF area.....	208
Computer.....	200, 203	Displaying vertically oriented images .....	155
Cont. Bracket.....	84	Display Media Info.....	219
Continuous AF.....	51	Display Rotation.....	155
Continuous shooting.....	79	DMF.....	51, 70
Contrast.....	125	D-Range Opt.....	112
Control wheel.....	30	Drive Mode.....	79
Cont. Shooting.....	79	DRO.....	112
Cont. Shoot. Length.....	81	DRO/Auto HDR.....	112, 113
Copy.....	159	DRO Bracket.....	88
Copyright Info.....	218	Dual Video REC.....	211
Creative Style.....	123		
C.Temp./Filter.....	120	<b>E</b>	
CTRL FOR HDMI.....	186	Edit Device Name.....	215
Ctrl w/ Smartphone.....	215	e-Front Curtain Shut.....	78
Custom Key (PB).....	170	Electronic Shut.....	75
Custom Key (Shoot.).....	170	Enlarge Image.....	154
Custom Setup.....	121	Enlarge Initial Pos.....	216
Custom white balance.....	121	Enlarge Init. Mag.....	216
		Entire Screen Avg.....	108
<b>D</b>		Expand Flexible Spot.....	53
Date/Time Setup.....	46	Exp. comp. set.....	209
Daylight.....	120	Exposure Comp.....	106
Deep.....	123	Exposure Set. Guide.....	213
Default values.....	189	Exposure Std. Adjust.....	209
Delete.....	162	Exposure step.....	209
Delete confirm.....	217	Extra fine.....	93
Delete Item.....	173	Eye AF.....	59
Del. Reg. AF Area.....	208		
Demo Mode.....	217		

Eye sensor .....	24
Eye-Start AF .....	208

## F

Face Detection .....	131
Face Registration .....	211
FEL lock .....	135
File Format .....	142
File Number .....	179
Fill-flash .....	133
Finder Color Temp. ....	217
Finder Frame Rate .....	177
FINDER/MONITOR .....	176
Fine .....	93
Flash .....	132
Flash bracket .....	84
Flash Comp. ....	134
Flash Mode .....	133
Flash Off .....	133
Flash sync terminal .....	138
Flexible Spot .....	53
Fluor.: Cool White .....	120
Fluor.: Daylight .....	120
Fluor.: Day White .....	120
Fn .....	31
Focus .....	51
Focus Area .....	53
Focus indicator .....	52
Focus-lock .....	50
Focus Magnifier .....	71
Focus Magnif. Time .....	210
Focus Mode .....	51
Focus Point Link .....	109
Focus Settings .....	207
Focus Standard .....	56
Folder Name .....	219
Format .....	178

FTP Transfer Func. ....	215
Function button .....	25, 31
Function Menu Set .....	171

## G

Grid Line .....	213
Guideframe .....	151

## H

HDMI Info. Display .....	184
HDMI Only (24p) .....	152
HDMI Only (25p) .....	152
HDMI Only (30p) .....	152
HDMI Resolution .....	183
HDMI Settings .....	183
HDR .....	113
Help Guide .....	2
High ISO NR .....	130
Highlight .....	108
Histogram .....	36

## I

Image Data Converter .....	203
Image Index .....	157
Image sensor .....	238
Image Size .....	92
Imp Root Certificate .....	215
In-Camera Guide .....	2
Incandescent .....	120
Index screen .....	157
Initial Focus Mag. ....	210
Intelligent Auto .....	47, 97
ISO .....	115
ISO AUTO .....	115
ISO AUTO Min. SS .....	116
ISO sensitivity .....	115



<b>L</b>	
Landscape .....	123
Language .....	218
Lens .....	43
Lens Comp.....	206
Light .....	123
List of icons .....	221
Live View Display .....	213
Location information .....	196
Location information linking .....	196
Lock-on AF .....	53
Lock Operation Parts .....	214
Long Exposure NR.....	129
<b>M</b>	
M .....	100
Manual Exposure .....	100
Manual Focus .....	51, 69
Marker Display .....	151
Marker Settings.....	151
Mass Storage.....	200
Memory.....	167
Memory card.....	41, 178, 246
Memory Card + HDMI .....	152
Memory recall .....	103
MENU.....	205
MENU button .....	24, 205
MENU items.....	206
Metering Mode .....	108
MF.....	51, 69
MF Assist .....	72
Mode dial .....	96
Monitor.....	35, 221
Monitor Brightness .....	217
Mount Adaptor .....	45, 240
Movie.....	104, 139
MOVIE Button.....	214
Movie file format.....	142
MOVIE (Movie) button .....	25, 139
Movie record setting.....	143
Movie w/ shutter .....	141
MP4 .....	143
MTP .....	200
Multi .....	108
Multi Interface Shoe.....	27
Multi-selector.....	31
My Menu .....	172, 220
<b>N</b>	
Network.....	214
Neutral.....	123
New Folder .....	219
NFC.....	190
Night Scene.....	123
Noise reduction.....	129
NR.....	129
NTSC/PAL Selector.....	217
<b>O</b>	
Obtaining location information.....	196
One-touch (NFC) .....	190
Operating sound.....	214
<b>P</b>	
P .....	98
Pairing .....	197
PC Remote .....	200
PC Remote Settings .....	187
Peaking Color .....	210
Peaking Level .....	73
Phase detection AF.....	55
Photo Capture.....	157
Picture Effect.....	210
Playback.....	153, 216

Playback speed .....	148
Playback zoom.....	154
Playing back movies .....	155
PlayMemories Home .....	203
PlayMemories Mobile .....	190
Portrait .....	123
Pre-AF.....	64
Printing.....	216
Printing the date .....	47
Priority Set in AF-C.....	65
Priority Set in AF-S .....	65
Priority Set in AWB .....	210
Program Auto.....	98
Program shift .....	98
Protect.....	161
Pwr Save Start Time .....	182

## Q

Quality.....	93
Quick Navi .....	32

## R

RAW.....	93, 94
RAW File Type .....	206
RAW images.....	93, 94
RAW + J PC Save Img .....	188
RAW & JPEG.....	93
Rear Sync.....	133
REC Control .....	185
Recordable number of images.....	247
Recordable time of movies .....	249
Recording Mode .....	180
Record Setting .....	143
Recover Image DB .....	219
Red Eye Reduction.....	209
Reg Cust Shoot Set .....	168
Release w/o Card .....	212

Release w/o Lens .....	212
Remote Camera Control .....	204
Remote Ctrl .....	182
Reset EV Comp.....	208
Reset Network Set.....	215
Rotate.....	216

## S

S .....	99
Safety Zone .....	151
Saturation.....	125
Scene recognition .....	97
Screen display.....	35
Select PB Media .....	159
Select REC Folder .....	181
Select Rec. Media.....	41, 219
Self-timer .....	82
Self-timer (Cont) .....	83
Self-timer Type.....	206
Send to Computer (Wi-Fi).....	214
Send to Smartphone.....	214
Sensitivity.....	115
Sepia .....	124
Set File Name .....	179
Setting Reset.....	189
Shade .....	120
Sharpness.....	125
Shooting still images .....	49
Shoot. Start Disp. .....	78
Shoot. Timing Disp.....	77
Shot. Result Preview .....	175
Shutter Priority.....	99
Shutter Type.....	74
Single Bracket .....	85
Single Shooting.....	79
Single-shot AF.....	51
Slideshow.....	160

Slow Sync.....	133	Vertical grip.....	244
Smart zoom.....	117	Video Light Mode.....	212
Software.....	203	Viewfinder.....	35
Sort Item.....	172	Viewfinder Bright.....	217
Specifications.....	252	Viewing images on a TV.....	164
Specify Printing.....	216	View Mode.....	158
Spot.....	108	View on TV (Wi-Fi).....	215
Spot focus.....	91	Vivid.....	123
Spot Metering Point.....	109	Volume.....	156, 217
S&Q.....	147	Volume Settings.....	156, 217
S&Q Motion.....	105		
S&Q Settings.....	147	<b>W</b>	
sRGB.....	126	Warning messages.....	234
SteadyShot.....	127	WB.....	120
SteadyShot Settings.....	127	WB bracket.....	87
Still Img. Save Dest.....	187	White Balance.....	120
Style Box.....	124	Wide.....	53
Sunset.....	123	Wi-Fi.....	190
Swt. V/H AF Area.....	57	Wi-Fi Settings.....	215
		Wind Noise Reduct.....	212
<b>T</b>		Wired LAN Setting.....	215
TC Output.....	184	Wireless flash.....	136
TC/UB Settings.....	218		
Touch Focus.....	90	<b>X</b>	
Touch function.....	90	XAVC S 4K.....	142
Touch Operation.....	90	XAVC S HD.....	142
<b>U</b>		<b>Z</b>	
Underwater Auto.....	120	Zebra.....	111
USB.....	200	Zone.....	53
USB Connection.....	200	Zoom.....	117
USB LUN Setting.....	218	Zoom Ring Rotate.....	213
USB Power Supply.....	187	Zoom scale.....	119
<b>V</b>			
Version.....	219		